

## Switch and Optional Extras

KG type up to 315 A



---

# Kraus & Naimer

The development of the Blue Line rotary switch and motor starter product ranges is based on more than hundred years experience by Kraus & Naimer in the design and manufacture of electrical switchgear. Kraus & Naimer pioneered the introduction of the cam operated rotary switch and continues to be recognized as the world leader in that product field.

## BLUE LINE

Blue Line products are protected by numerous patents through-out the industrial world. They are built to national and international standards and designed to withstand adverse temperatures and climates.

Blue Line products are accepted and universally recognized for their quality and workmanship. They are supported by a worldwide sales and service organization.

The Kraus & Naimer Registered Trademark

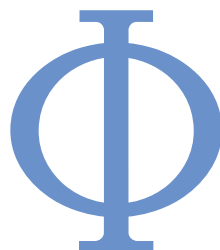

WORLDWIDE SYMBOL  
FOR QUALITY SWITCHGEAR

---

---

Disconnectors and Main Switches acc. to IEC 60947-3 see Catalog 500

<b>Contents</b>	<b>KG Switches</b>
	Page
Construction Data	4
Nominal Ratings	5
How to order	6, 7
Types of Mounting and Enclosures	8-10
Switch Function and Configuration	11-13
Face plates	14
Handles	15
Optional Extras	
Shaft Extensions	18
Auxiliary Contacts	16
Protective Covers	16
Ground and Neutral Terminals	17
Padlock Devices	20
Door Clutches	18, 19
Additional Main Contacts	17
Additional Module for Motor Control Center (MCC)	21
Angular drive	21
Technical Data	22, 23
Tightening torque of screws	23
International Standards and Approvals	24
Dimensions	
Types of Mounting and Enclosures	25-28
Optional Extras	29-34
Blue Line Switchgear: Summary	36

---

The KG10A through KG317 switch line offers excellent performance characteristics and exceed the requirements of IEC 60947-3 as well as the new VDE 0660 part 107. KG switches are principally used as motor and industrial panel disconnectors, double-throw transfer switches, safety switches, main disconnect switches and distribution system isolation switches. This durable switch line possesses high short-circuit withstand capabilities, with positive contact movement during making and breaking functions. KG switches exhibit excellent AC-3 and AC-23 making and breaking capabilities providing an additional safety advantage.

The safety level of the KG switch series in numerous areas surpasses those of many international standards organizations: Positive contact movement during making and breaking operations. Higher dimensioned air and creepage distances for 690 V or 1000 V. Dead front, finger-proof box terminals according to EN 50274, VDE 0660 part 514 and DGUV V3. Switch types KG210, KG250 and KG315 require an option protective cover.

This advanced switch-generation affords significant advantages during mounting and wiring. For ease of installation, switch terminals are on the same plane as the power conductors. The KG10A through KG105C base mounted switches feature a two hole mounting as well as a "quick mount" designed for standard DIN







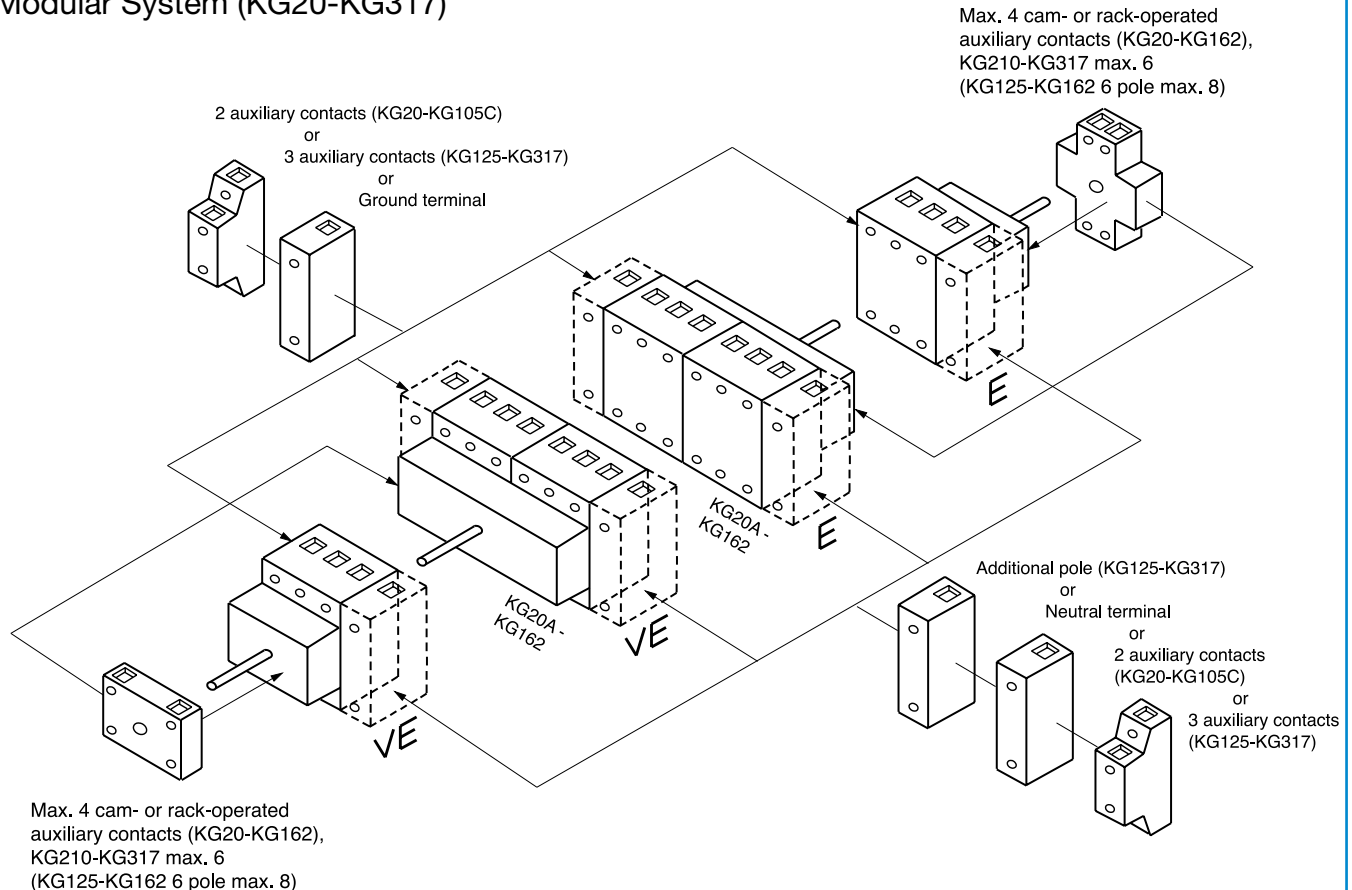





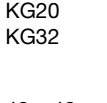
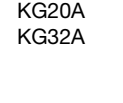
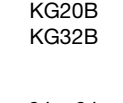

rails according to EN 50022. KG125 through KG317 feature a four hole mounting.

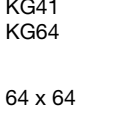
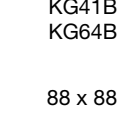
The flexibility of the KG's modular system offers maximum versatility for the modifying of switches in the field. Modules can easily be added to switches which have already been installed in equipment often without having to remove existing wiring. This modular design also minimizes the need for high inventory levels. Other important accessories such as make before break auxiliary contacts, additional box and bolt terminals, shaft extensions, door clutches, terminal covers and padlock devices enhance the flexibility and versatility of this proven line of switches.

**Modular System (KG20-KG317)**

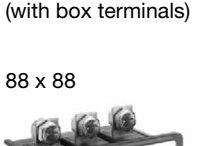
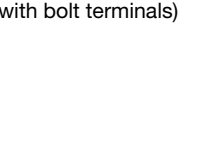
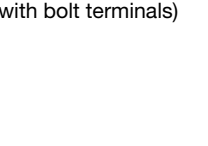

## Nominal Ratings

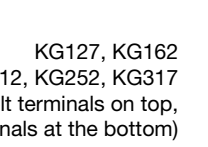
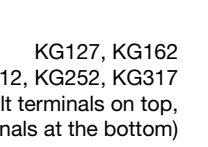
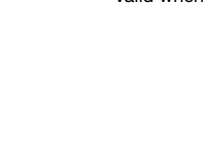
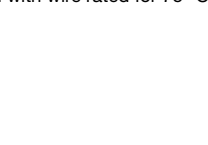
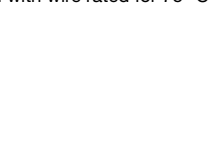
Face plate Frame mm	Typen	IEC 60947-3/VDE 0660 part 107			UL and Canada	
		Rated Values	Utilization Category	Ampere-Rating	Standard Motor Load DOL-Rating	
		Thermal Current $I_U/I_{th}$ <b>A</b>	AC-23A <b>kW</b>	AC-3 <b>A</b>	3 x 240 V <b>HP</b>	3 x 480 V <b>HP</b>
48 x 48	 KG10A	20	5,5	3,7	2	3
64 x 64	 KG10B	20	5,5	3,7	2	3
30 x 30	 KG20	25	7,5	5,5	7,5	15
48 x 48	 KG20A	25	7,5	5,5	7,5	15
64 x 64	 KG20B	25	7,5	5,5	7,5	15
	 KG32	32	11	7,5	10	20
	 KG32A	32	11	7,5	10	20
	 KG32B	32	11	7,5	10	20
48 x 48	 KG41	40	15	11	15	25
64 x 64	 KG41B	40	15	11	15	25
	 KG64	63	22	18,5	15	30
	 KG64B	63	22	18,5	15	30
64 x 64	 KG80	80	30	22	25	50
88 x 88	 KG80C	80	30	22	25	50
	 KG100	100	37	30	25	50
	 KG100C	100	37	30	25	50
	 KG105	125	45	37	40	60
	 KG105C	125	45	37	40	60
88 x 88	 KG125, KG160	125	45	37	30	60
	 KG126, KG161	125	45	37	30	60
	 KG127, KG162	125	45	37	30	60
	 KG210, KG250, KG315 (with box terminals)	200	75	55	50	75
	 KG211, KG251, KG316 (with bolt terminals)	200	75	55	50	75
	 KG212, KG252, KG317 (bolt terminals on top, box terminals at the bottom)	200	75	55	50	75
88 x 88	 KG250	250	90	55	60	75
	 KG251	250	90	55	60	75
	 KG252	250	90	55	60	75
	 KG315	315	110	75	75	100
	 KG316	315	110	75	75	100
	 KG317	315	110	75	75	100

<sup>1</sup>Valid when connected with wire rated for 75 °C.

## How to order

Disconnectors and Main Switches according to IEC 60947-3 see Catalog 500

Three or four pieces of data (shown below) are required for ordering Blue Line Switch Disconnectors. Code numbers for ordering are shown in this catalog.

### 1. Type of Switch

The type of switch required may be easily selected by referring to the tables on pages 5 which show the thermal current and power rating of each switch. For further technical details, refer to pages 22/23.

### 2. Switch Function

The code numbers shown on pages 11-13 indicate the switch function, face plates and handles. Additional coding to modify the type and color of handle and face plate is explained below and on page 7.

### 3. Type of Mounting

Switch types and enclosures for the KG switches are shown on pages 8-10.

**KG100**

**K302  
M004**

**VE**

### 4. Optional Extras

Pages 16-21 list optional extras and their coding for the KG switches. A table shows the different switch sizes in which the optional extra is available.

There are some optional extras which are available in a variety of programs. Additional ordering data may, therefore, be required.

### Handles, Face plates and Optional Extras

Various standards are listed in the table on pages 8-10.

When a handle, face plate or optional extra is required but not covered by the standard code number, the code number for the selected component should be entered separately. A complete range of standard face plates are illustrated on pages 14/15. Non standard or special face plate engravings are available at extra cost.



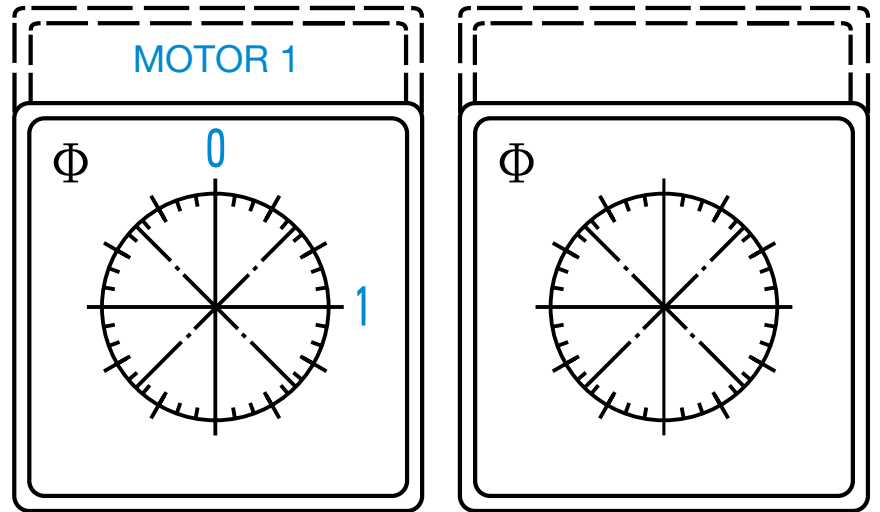

## How to order

### Ordering of Special Face plates



When ordering special escutcheon plates it is advisable to use our order form, as illustrated. **Example:** Customer's requirements are shown beside these two numbers with a digit number which represents the color combination required.

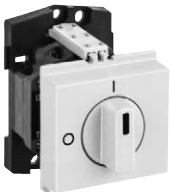

Order forms are available upon request.



Mounting	Type	Code
 <p><b>Front mounting</b></p> <p>Two hole panel mounting, Protection IP 66/67</p> <p>Four hole panel mounting, Protection IP 66/67 Protection IP 66/67</p>	<p>KG20 KG32</p> <p>KG10A KG41- KG100 KG160- KG315</p>	<p><b>E</b></p> <p><b>E</b></p>
 <p><b>Single hole mounting 22 mm</b></p> <p>Without face plate, Protection IP 66/67/69k</p>	<p>KG10A KG20A KG32A</p>	<p><b>FT1</b></p>
 <p>With square face plate, Protection IP 66/67/69k</p>	<p>KG10A KG20A KG32A</p>	<p><b>FT2</b></p>
 <p><b>Base mounting</b></p> <p>Screw/Snap-on base mounting for track EN 50022, Protection IP 40</p> <p>Snap-on base mounting for track EN 50022, Protection IP 40</p>	<p>KG10A- KG317</p> <p>KG125- KG162</p>	<p><b>VE</b></p> <p><b>VE1</b></p>
 <p>Screw base mounting (KG20A-KG162) and Snap-on base mounting (KG20A-KG105) for track EN 50022. Face plate for 45 mm knock-out. Protection IP 40</p>	<p>KG20A KG32A KG41- KG64B KG80- KG105 KG125- KG162</p>	<p><b>VE2</b></p>
 <p>Snap-on base mounting for track EN 50022. Both the face plate for 45 mm standard knock-out and the handle are adjustable in height. Protection IP 40</p>	<p>KG10A</p>	<p><b>VE21</b></p>

[< back to table of contents >](#)

Plastic Enclosure Protection IP 66		Type	Code	
	<p>The KL and CL enclosures are available in 3 sizes allowing for installation of 3, 4, 6 and 8 pole KG switches. The KL-series is made of strong durable plastic and offers high UV-resistance. All KL- and KS-enclosures are flame resistant in accordance with UL94V-0. The CL-series is especially designed for applications in an aggressive environment, such as oil, chemical substances and grease. Each enclosure has 2 knock-outs on top and bottom for metric thread according to EN 50262. Included in each enclosure is a ground and neutral terminal. One of these terminals must be eliminated if a 3 pole switch with lateral mounted auxiliary contacts or a 4 pole switch is installed.</p> <p>All enclosures can be supplied with a cover coupling for additional safety. Increased wiring space and mounting holes with slots are featured in this new line. These enclosures are also available for conduit entries for PG-thread.</p>	<p>KG20                      KG32                      KG20B                      KG32B                      KG41                      KG64                      KG41B                      KG64B                      KG80                      KG100                      KG105</p>		
	Without cover interlock		<p><b>KL.0</b>  <b>CL.0</b></p>	
	With cover interlock (The enclosure can only be opened at 9 o'clock position)		<p><b>KL.1</b>  <b>CL.1</b></p>	
	With cover interlock (The enclosure can only be opened at 12 o'clock position)		<p><b>KL.2</b>  <b>CL.2</b></p>	
		<p>KS and CS enclosures have a compact size which allows for the installation of a 3, 4 or 6 pole KG10 ON/OFF switch or a 3 pole KG20 ON/OFF switch. The design, options and mounting are the same as those of the KL and CL enclosures.</p>	<p>KG10                      KG20</p>	
		Without cover interlock		<p><b>KS50</b>  <b>CS50</b></p>
		With cover interlock (The enclosure can only be opened at 9 o'clock position)		<p><b>KS51</b>  <b>CS51</b></p>
		With cover interlock (The enclosure can only be opened at 12 o'clock position)		<p><b>KS52</b>  <b>CS52</b></p>

[< back to table of contents >](#)

Plastic Enclosure with Ground Terminal Protection IP 65 resp. IP 54	Threads	Type	Code
---	---------	------	------

 <p>KG20A, KG32A, KG41, KG64 3 and 4 pole (ON/OFF Switches) Protection IP 65</p>	<p><b>Conduit entries with NPT-thread, Protection 65</b></p>		<p>KG20A KG32A KG41 KG64</p>	<p><b>PFA5</b> <b>PFA1</b> <b>PFD5</b> <b>PFD1</b></p> <p><b>PFB5</b> <b>PFB1</b> <b>PFE5</b> <b>PFE1</b></p> <p><b>PFC5</b> <b>PFC1</b> <b>PFF5</b> <b>PFF1</b></p>		
	Without cover coupling	M20				
	And for switches with cam-operated auxiliary contacts	M25				
	With cover coupling	M20				
	And for switches with cam-operated auxiliary contacts	M25				
	Without cover coupling, combined with padlock device V840A	M20				
	And for switches with cam-operated auxiliary contacts	M25				
	<p><b>Conduit entries with NPT-thread, Protection 54</b></p>				<p>KG20B KG32B KG41B KG64B KG80 KG100</p>	<p><b>PFA4</b></p> <p><b>PFD4</b></p> <p><b>PFB4</b></p> <p><b>PFE4</b></p> <p><b>PFC4</b></p> <p><b>PFF4</b></p>
	Without cover coupling	M25				
	And for switches with cam-operated auxiliary contacts	M25				
With cover coupling	M25					
And for switches with cam-operated auxiliary contacts	M25					
Without cover coupling, combined with padlock device V840A	M25					
And for switches with cam-operated auxiliary contacts	M25					
 <p>KG80, KG100 3 and 4 pole<sup>1</sup> (ON/OFF Switches) KG20B, KG32B, KG41B, KG64B 6 and 8 pole (ON/OFF Switches) 3 and 4 pole (Double-throw Switches) Protection IP 54 On top and at the bottom an additional conduit entry M16</p>						

[< back to table of contents >](#)

<sup>1</sup>For switches with cam-operated auxiliary contacts only 3 pole.

Function	KG10A	KG10B	KG20 KG32	KG20A KG32A	KG20B KG32B	KG41 KG64	KG41B KG64B	KG80 KG100 KG105	KG80C KG100C KG105C	KG125- KG317	Escutch. Plate	Code
----------	-------	-------	--------------	----------------	----------------	--------------	----------------	------------------------	---------------------------	-----------------	-------------------	------

ON/OFF Switches 3 pole

Types of Mounting

Without auxiliary contacts	E FT1 FT2 VE  VE21  KS. <sup>2</sup>	E  VE  VE	E  VE  VE  KL. KS. <sup>1</sup>	E FT1 FT2 VE VE2  PF..	E  VE  VE	E  VE VE2  KL. PF..	E  VE VE2  KL. PF.. <sup>4</sup>	E  VE VE2  KL. PF.. <sup>4</sup>	E  VE VE2  KL. PF.. <sup>4</sup>	E  VE VE1 <sup>3</sup> VE2 <sup>3</sup>		<b>K300</b>
With cam/rack-operated auxiliary contact 1 NO	E FT1 FT2 VE  VE21  KS. <sup>2</sup>	E  VE  VE	E  VE  VE  KL.	E FT1 FT2 VE VE2  PF..	E  VE  VE	E  VE VE2  KL. PF..	E  VE VE2  KL. PF.. <sup>4</sup>	E  VE VE2  KL. PF.. <sup>4</sup>	E  VE VE2  KL. PF.. <sup>4</sup>	E  VE VE1 <sup>3</sup>		<b>K301</b>
With cam/rack-operated auxiliary contacts 1 NO and 1 NC	E FT1 FT2 VE  VE21  KS. <sup>2</sup>	E  VE  VE	E  VE  VE  KL.	E FT1 FT2 VE VE2  PF..	E  VE  VE	E  VE VE2  KL. PF..	E  VE VE2  KL. PF.. <sup>4</sup>	E  VE VE2  KL. PF.. <sup>4</sup>	E  VE VE2  KL. PF.. <sup>4</sup>	E  VE VE1 <sup>3</sup>		<b>K302</b>
With cam/rack-operated auxiliary contacts 2 NO			E  VE  KL.	E FT1 FT2 VE VE2  PF..	E  VE  VE	E  VE VE2  KL. PF..	E  VE VE2  KL. PF.. <sup>4</sup>	E  VE VE2  KL. PF.. <sup>4</sup>	E  VE VE2  KL. PF.. <sup>4</sup>	E  VE VE1 <sup>3</sup>		<b>K312</b>
With lateral mounted auxiliary contacts 1 NO and 1 NC			E  VE  KL.	E FT1 FT2 VE VE2  PF..	E  VE  VE	E  VE VE2  KL. PF..	E  VE VE2  KL. PF.. <sup>4</sup>	E  VE VE2  KL. PF.. <sup>4</sup>	E  VE VE2  KL. PF.. <sup>4</sup>	E  VE VE2  KL. PF.. <sup>4</sup>		<b>K304</b>
With GRD-terminal			E  VE	E FT1 FT2 VE VE2	E  VE	E  VE VE2	E  VE VE2	E  VE VE2	E  VE VE2	E  VE VE1 <sup>3</sup> VE2 <sup>3</sup>		<b>K305</b>
With GRD- and N-terminal			E  VE	E FT1 FT2 VE VE2	E  VE	E  VE VE2	E  VE VE2	E  VE VE2	E  VE VE2	E  VE VE1 <sup>3</sup> VE2 <sup>3</sup>		<b>K307</b>

[< back to table of contents >](#)

<sup>1</sup>Only for switch type KG20. <sup>2</sup>When using KS. the switch type changes to KG10. <sup>3</sup>Only for switch types KG125-KG162. <sup>4</sup>Only for switch types KG80 and KG100.

Function	KG10A	KG10B	KG20 KG32	KG20A KG32A	KG20B KG32B	KG41 KG64	KG41B KG64B	KG80 KG100 KG105	KG80C KG100C KG105C	KG125- KG317	Escutch. Plate	Code
----------	-------	-------	--------------	----------------	----------------	--------------	----------------	------------------------	---------------------------	-----------------	-------------------	------

ON/OFF Switches 4 pole

Types of Mounting

Without auxiliary contacts	E FT1 FT2 VE  VE21  KS. <sup>1</sup>	E  VE	E  VE  KL.	E FT1 FT2 VE VE2  PF..	E  VE	E  VE VE2  KL.  PF..	E  VE VE2  KL.  PF.. <sup>3</sup>	E  VE VE2  KL.  PF.. <sup>3</sup>	E  VE VE2  KL.  PF.. <sup>3</sup>	E  VE VE1 <sup>2</sup> VE2 <sup>2</sup>		<b>K400</b>
With cam-operated auxiliary contact 1 NO			E VE KL.	E FT1 FT2 VE VE2 PF..	E  VE	E  VE VE2 KL. PF..	E  VE VE2  KL.  PF.. <sup>3</sup>	E  VE VE2  KL.  PF.. <sup>3</sup>	E  VE VE2  KL.  PF.. <sup>3</sup>	E  VE VE1 <sup>2</sup>		<b>K401</b>
With cam-operated auxiliary contacts 1 NO and 1 NC	E FT1 FT2 VE  VE21  KS. <sup>1</sup>	E  VE	E  VE  KL.	E FT1 FT2 VE VE2 PF..	E  VE	E  VE VE2  KL.  PF..	E  VE VE2  KL.  PF.. <sup>3</sup>	E  VE VE2  KL.  PF.. <sup>3</sup>	E  VE VE2  KL.  PF.. <sup>3</sup>	E  VE VE1 <sup>2</sup>		<b>K402</b>
With lateral mounted auxiliary contacts 1 NO and 1 NC			E VE	E FT1 FT2 VE VE2 PF..	E  VE	E  VE VE2  KL.  PF.. <sup>3</sup>	E  VE VE2  KL.  PF.. <sup>3</sup>	E  VE VE2  KL.  PF.. <sup>3</sup>	E  VE VE2  KL.  PF.. <sup>3</sup>	E  VE VE2  KL.  PF.. <sup>3</sup>		<b>K404</b>

ON/OFF Switches 6 pole

Without auxiliary contacts	E FT1 FT2 VE VE21  KS. <sup>1</sup>	E  VE		E  VE VE2  KL.  PF..	E  VE VE2  KL.  PF..		E  VE VE2  KL.  PF..	E  VE VE2  KL.  PF..	E  VE VE2  KL.  PF..	E <sup>2</sup>  VE <sup>2</sup> VE1 <sup>2</sup>		<b>K600</b>
With cam-operated auxiliary contact 1 NO				E VE VE2  KL. PF..	E VE VE2  KL. PF..		E VE VE2  KL. PF..	E VE VE2  KL. PF..	E VE VE2  KL. PF..	E <sup>2</sup>  VE <sup>2</sup> VE1 <sup>2</sup>		<b>K601</b>
With cam-operated auxiliary contacts 1 NO and 1 NC	E FT1 FT2 VE VE21  KS. <sup>1</sup>	E  VE		E  VE VE2  KL.  PF..	E  VE VE2  KL.  PF..		E  VE VE2  KL.  PF..	E  VE VE2  KL.  PF..	E  VE VE2  KL.  PF..	E <sup>2</sup>  VE <sup>2</sup> VE1 <sup>2</sup>		<b>K602</b>

<sup>1</sup>When using KS. the switch type changes to KG10. <sup>2</sup>Only for switch types KG125-KG162. <sup>3</sup>Only for switch types KG80 and KG100.

Function	KG10A	KG10B	KG20A KG32A	KG20B KG32B	KG41B KG64B	KG80 KG100 KG105	KG80C KG100C KG105C	KG125- KG162	Escutch. Plate	Code
----------	-------	-------	----------------	----------------	----------------	------------------------	---------------------------	-----------------	-------------------	------

ON/OFF Switches 8 pole

Types of Mounting

Without auxiliary contacts			E VE VE2	E VE KL. PF..	E VE VE2 KL. PF..	E VE VE2	E VE	E VE VE1		K800
----------------------------	--	--	----------------	------------------------	-------------------------------	----------------	---------	----------------	--	------

Double-throw Switches 3 pole

Without auxiliary contacts			E VE VE2	E VE KL. PF..	E VE VE2 KL. PF..	E VE VE2	E VE	E VE VE1		K900
----------------------------	--	--	----------------	------------------------	-------------------------------	----------------	---------	----------------	--	------

Double-throw Switches 4 pole

Without auxiliary contacts			E VE VE2	E VE KL. PF..	E VE VE2 KL. PF..	E VE VE2	E VE	E VE VE1		K950
----------------------------	--	--	----------------	------------------------	-------------------------------	----------------	---------	----------------	--	------

[< back to table of contents >](#)

Connection Diagrams

**ON/OFF Switches 3 pole (with cam-operated auxiliary contacts)**

**ON/OFF Switches 4 pole (with cam-operated auxiliary contacts)**

**ON/OFF Switches 6 pole (with cam-operated auxiliary contacts)**

**With lateral mounted auxiliary contacts**

Mounting E, FT1, FT2

**With lateral mounted auxiliary contacts**

Mounting E, FT1, FT2

**ON/OFF Switches 8 pole**

VE, VE2, KL., PF..

**Double-throw Switches 3 pole**

**Double-throw Switches 4 pole**

Square and rectangular face plates are available for each size of switch. The face plate consists of a frame and a faceplate having the switch position which is then embossed with hot-foil backing. The face plate frame is an essential part of the switch and serves as a bearing surface for the handle. If the switch is to be mounted without an face plate we would recommend the handle bearing plate T100-04, which is available for switch types KG10B, KG20B, KG32B, KG41B, KG80, KG100, KG105, KG80C, KG100C, KG105C and KG125-KG317. Face plates with special lettering are also available upon request.





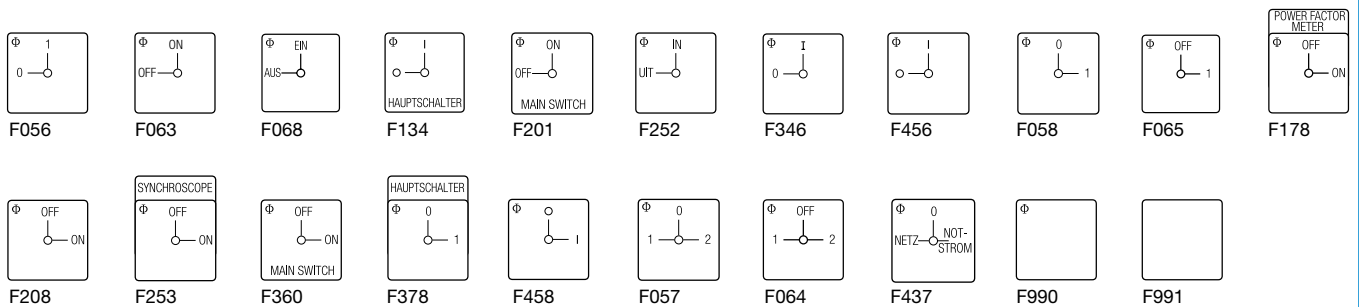



Standard Face plates



<sup>1</sup>Not available for switch types KG20 and KG32.

# Handles



# KG Switches

Type	Color	Code	KG20 KG32	KG10A- KG64	KG10B- KG105	KG80C- KG105C	KG125- KG162	KG210- KG317
I-Handle 	black red	G251 G252	● ●	● ●	● ●	● ●	● ●	— —
B-Handle 	black red	G521 G522	— —	● ●	● ●	— —	— —	— —
R-Handle 	black red	G001 G002	— —	● ●	● ●	● ●	● ●	— —
F-Handle 	black red	G221 G222	● ●	● ●	● ●	● ●	● ●	— —
L-Handle 	black red	G501 G502	— —	— —	● ●	— —	— —	— —
P-Handle  KG10A-KG64    KG10B-KG317	black red	G211 G212	— —	● ●	● ●	● ●	● ●	● ●
K-Handle 	black red	G411 G412	— —	— —	● ●	● ●	● ●	● ●



< back to table of contents >

<b>Protective Covers, Auxiliary Contacts</b>	Type	Code
--	------	------

**Protective Covers**



	For 3 resp. 4 main contacts	KG10A KG10B	<b>M160/A12 K2</b>
	For 3 main contacts with box terminal with bolt terminal	KG20- KG315 KG126 KG161 KG211 KG251 KG316	<b>M160/3.</b> <b>M160/33</b> <b>M160/31</b>
	For 4 main contacts with box terminal	KG20- KG315 KG126 KG161 KG211 KG251 KG316	<b>M160/4.</b> <b>M160/43</b> <b>M160/41</b>
	with bolt terminal		







**Cam- and rack-operated Auxiliary Contacts** (mounting only at factory)

	Cam-operated auxiliary contacts Up to 4 cam-operated auxiliary contacts can be added to all switches.	KG20- KG105C	<b>M510A</b>
	Select between a contact system with a rigid contact bridge for excellent AC-15 making and breaking capabilities or a H-bridge design with "cross-wire" contacts for low voltages and currents (mounting E from KG41 and mounting VE from KG80). The contact systems with gold contacts or gold-plated contacts allow for use in aggressive environments also. Special programs are also available upon request.		
	Rack-operated auxiliary contacts Switch types KG125-KG162 can be supplied with up to 4 auxiliary contacts, KG210-KG317 with up to 6 auxiliary contacts.	KG125- KG317	<b>M510B</b>
	Ordering data:	Quantity and operation of the auxiliary contacts and type of the contact system.	

[< back to table of contents >](#)

**Lateral mounted Auxiliary Contacts**

	Lateral mounted auxiliary contacts with 1 NO and 1 NC.	KG20- KG105C	<b>H010/A11-E</b> <b>H010/A11-VE</b>  <b>H010/B11-E</b> <b>H010/B11-VE</b>																			
	<table border="0"> <tr> <td></td> <td colspan="2" style="text-align: center;">Terminal numbers Attachment</td> </tr> <tr> <td>Standard contacts (nonoverlapping)</td> <td>left</td> <td>right</td> </tr> <tr> <td>For mounting E, FT1 and FT2</td> <td>(33-34, 41-42)</td> <td>(53-54, 61-62)</td> </tr> <tr> <td>For mounting VE, VE2, KL. and PF..</td> <td>(31-32, 43-44)</td> <td>(51-52, 63-64)</td> </tr> <tr> <td>Overlapping contacts</td> <td></td> <td></td> </tr> <tr> <td>For mounting E, FT1 and FT2</td> <td>(33-34, 41-42)</td> <td>(53-54, 61-62)</td> </tr> <tr> <td>For mounting VE, VE2, KL. and PF..</td> <td>(31-32, 43-44)</td> <td>(51-52, 63-64)</td> </tr> </table>			Terminal numbers Attachment		Standard contacts (nonoverlapping)	left	right	For mounting E, FT1 and FT2	(33-34, 41-42)	(53-54, 61-62)	For mounting VE, VE2, KL. and PF..	(31-32, 43-44)	(51-52, 63-64)	Overlapping contacts			For mounting E, FT1 and FT2	(33-34, 41-42)	(53-54, 61-62)	For mounting VE, VE2, KL. and PF..	(31-32, 43-44)
	Terminal numbers Attachment																					
Standard contacts (nonoverlapping)	left	right																				
For mounting E, FT1 and FT2	(33-34, 41-42)	(53-54, 61-62)																				
For mounting VE, VE2, KL. and PF..	(31-32, 43-44)	(51-52, 63-64)																				
Overlapping contacts																						
For mounting E, FT1 and FT2	(33-34, 41-42)	(53-54, 61-62)																				
For mounting VE, VE2, KL. and PF..	(31-32, 43-44)	(51-52, 63-64)																				
	Lateral mounted auxiliary contacts with 2 NO and 1 NC.	KG125- KG317	<b>H010/A21-E</b> <b>H010/A21-VE</b>  <b>H010/B21-E</b> <b>H010/B21-VE</b>																			
	<table border="0"> <tr> <td></td> <td colspan="2" style="text-align: center;">Terminal numbers Attachment</td> </tr> <tr> <td>Standard contacts (nonoverlapping)</td> <td>left</td> <td>right</td> </tr> <tr> <td>For mounting E</td> <td>(013-014, 023-024, 031-032)</td> <td>(043-044, 053-054, 061-062)</td> </tr> <tr> <td>For mounting VE</td> <td>(011-012, 023-024, 033-034)</td> <td>(041-042, 053-054, 063-064)</td> </tr> <tr> <td>Overlapping of 1 NO and 1 NC</td> <td></td> <td></td> </tr> <tr> <td>For mounting E</td> <td>(013-014, 023-024, 031-032)</td> <td>(043-044, 053-054, 061-062)</td> </tr> <tr> <td>For mounting VE</td> <td>(011-012, 023-024, 033-034)</td> <td>(041-042, 053-054, 063-064)</td> </tr> </table>			Terminal numbers Attachment		Standard contacts (nonoverlapping)	left	right	For mounting E	(013-014, 023-024, 031-032)	(043-044, 053-054, 061-062)	For mounting VE	(011-012, 023-024, 033-034)	(041-042, 053-054, 063-064)	Overlapping of 1 NO and 1 NC			For mounting E	(013-014, 023-024, 031-032)	(043-044, 053-054, 061-062)	For mounting VE	(011-012, 023-024, 033-034)
	Terminal numbers Attachment																					
Standard contacts (nonoverlapping)	left	right																				
For mounting E	(013-014, 023-024, 031-032)	(043-044, 053-054, 061-062)																				
For mounting VE	(011-012, 023-024, 033-034)	(041-042, 053-054, 063-064)																				
Overlapping of 1 NO and 1 NC																						
For mounting E	(013-014, 023-024, 031-032)	(043-044, 053-054, 061-062)																				
For mounting VE	(011-012, 023-024, 033-034)	(041-042, 053-054, 063-064)																				

Ground and Neutral Terminals	Type	Code	Additional Main Contacts	Type	Code																
<p>Ground terminal</p>  	KG20- KG32B	<b>K0 H052/A</b>	 <p><b>Terminals for Control Circuit</b></p>  <p>Max. Permissible Wire Gage Single-core or Flexible wire stranded wire</p> <table border="1"> <tr> <td>2,5 mm<sup>2</sup> AWG12</td> <td>2,5 mm<sup>2</sup> AWG14</td> <td>KG41- KG64B</td> <td><b>K1B D220 KS</b></td> </tr> <tr> <td>2,5 mm<sup>2</sup> AWG12</td> <td>2,5 mm<sup>2</sup> AWG14</td> <td>KG80- KG105C</td> <td><b>K2B D520 KSA</b></td> </tr> <tr> <td>4 mm<sup>2</sup> AWG10</td> <td>4 mm<sup>2</sup> AWG12</td> <td>KG125- KG162</td> <td><b>K3A D720 KS</b></td> </tr> <tr> <td>4 mm<sup>2</sup> AWG10</td> <td>4 mm<sup>2</sup> AWG12</td> <td>KG210- KG317</td> <td><b>K3B D520 KS</b></td> </tr> </table> <p><b>Wiring Aid</b></p>  <p>Ordering data: Switch moun- ting.</p>	2,5 mm <sup>2</sup> AWG12	2,5 mm <sup>2</sup> AWG14	KG41- KG64B	<b>K1B D220 KS</b>	2,5 mm <sup>2</sup> AWG12	2,5 mm <sup>2</sup> AWG14	KG80- KG105C	<b>K2B D520 KSA</b>	4 mm <sup>2</sup> AWG10	4 mm <sup>2</sup> AWG12	KG125- KG162	<b>K3A D720 KS</b>	4 mm <sup>2</sup> AWG10	4 mm <sup>2</sup> AWG12	KG210- KG317	<b>K3B D520 KS</b>	KG125 KG126 KG127	<b>K3 H050/P<sup>1</sup></b> <b>K3 H050/Q<sup>1</sup></b> <b>K3 H050/R<sup>1</sup></b>
	2,5 mm <sup>2</sup> AWG12	2,5 mm <sup>2</sup> AWG14		KG41- KG64B	<b>K1B D220 KS</b>																
	2,5 mm <sup>2</sup> AWG12	2,5 mm <sup>2</sup> AWG14		KG80- KG105C	<b>K2B D520 KSA</b>																
	4 mm <sup>2</sup> AWG10	4 mm <sup>2</sup> AWG12		KG125- KG162	<b>K3A D720 KS</b>																
	4 mm <sup>2</sup> AWG10	4 mm <sup>2</sup> AWG12		KG210- KG317	<b>K3B D520 KS</b>																
	KG41- KG64B	<b>K1 H052/B</b>		KG160 KG161	<b>K3 H050/S<sup>1</sup></b> <b>K3 H050/T<sup>1</sup></b> <b>K3 H050/U<sup>1</sup></b>																
	KG80- KG105C	<b>K2 H052/C</b>		KG210 KG250 KG251	<b>K3 H050/G<sup>1</sup></b> <b>K3 H050/H<sup>1</sup></b> <b>K3 H050/J<sup>1</sup></b>																
	KG125 KG160	<b>K3 H052/H<sup>1</sup></b>		KG212 KG252																	
	KG126 KG161	<b>K3 H052/J<sup>1</sup></b>		KG316 KG317	<b>K3 H050/K<sup>1</sup></b> <b>K3 H050/L<sup>1</sup></b> <b>K3 H050/M<sup>1</sup></b>																
	KG127 KG162	<b>K3 H052/K<sup>1</sup></b>		KG20- KG32B																	
	KG210 KG250 KG315	<b>K3 H052/D<sup>1</sup></b>		KG41- KG64B																	
	KG211 KG251	<b>K3 H052/E<sup>1</sup></b>		KG80- KG100C																	
	KG212 KG252	<b>K3 H052/F<sup>1</sup></b>		KG125 KG160																	
	KG316 KG317	<b>K3 H052/L<sup>1</sup></b> <b>K3 H052/M<sup>1</sup></b>		KG126 KG161																	
	<p>Neutral terminal</p>  	KG20- KG32B		<b>K0 H053/A</b>																	
KG41- KG64B		<b>K1 H053/B</b>																			
KG80- KG100C		<b>K2 H053/C</b>																			
KG125 KG160		<b>K3 H053/H<sup>1</sup></b>																			
KG126 KG161		<b>K3 H053/J<sup>1</sup></b>																			
KG127 KG162		<b>K3 H053/K<sup>1</sup></b>																			
KG210 KG250 KG315		<b>K3 H053/D<sup>1</sup></b>																			
KG211 KG251		<b>K3 H053/E<sup>1</sup></b>																			
KG212 KG252		<b>K3 H053/F<sup>1</sup></b>																			
KG316 KG317		<b>K3 H053/L<sup>1</sup></b> <b>K3 H053/M<sup>1</sup></b>																			

< back to table of contents >

<sup>1</sup>Mounting only at factory.

Shaft Extensions, Simplified Door Clutch	Type	Code
--	------	------

**Shaft Extensions**

	<p>With asymmetric profile Shaft length not adjustable</p> <p>Shaft with adjustable length with set screw with shear ring</p> <p>With square profile Shaft length not adjustable</p> <p>Shaft with adjustable length with set screw with clamping bushing</p>	<p>KG10B KG20B, KG32B KG41B- KG105C</p> <p>KG10A KG20A, KG32A KG41-KG317</p> <p>KG10B KG20B, KG32B KG41B- KG105C</p>	<p><b>L100</b></p> <p><b>M004D</b> <b>M004</b></p> <p><b>L100A</b></p> <p><b>M004E</b> <b>M004A</b></p>
<p>Ordering data:</p>	<p>Free shaft length or dimension from mounting surface to cover.</p>	<p>KG41B-KG317 KG125-KG317</p>	



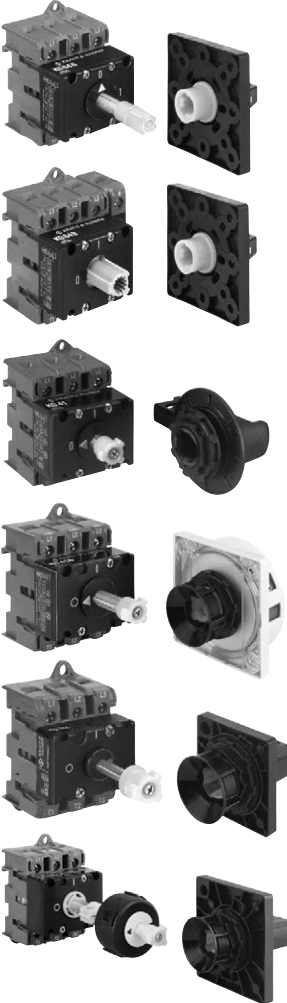

**Simplified Door Clutch**

	<p>The simplified door clutches are utilized primarily when the switch is mounted to the bottom of the enclosure and the handle and face plate are mounted on the cover.</p> <p>With shaft extension Front protection IP 40 Front protection IP 65</p> <p>With profile extension parts Front protection IP 65</p> <p>With padlock device, single hole mounting 22 mm, protection IP 66. An additional aluminum shaft extension is required.</p> <p>Loc bar is accessible from 3 o'clock which achieve a compact design.</p> <p>The cover disc is available in black, yellow and electro-gray. The handle may be supplied in black, red and electro-gray.</p> <p>Operation of the locking bar from the front. Available in black, red and electro-gray.</p> <p>Centering device for simplified door clutches with single hole mounting and shaft extension Misalignment between the shaft and mounting are compensated in all 4 directions.</p>	<p>KG10A KG20A, KG32A KG41B-KG105</p> <p>KG41B-KG105</p> <p>KG10B KG20B, KG32B KG41B-KG105, KG125-KG317<sup>2</sup></p> <p>KG10B KG20B, KG32B KG41B-KG105</p> <p>KG10A KG20A, KG32A KG41, KG64 KG10B KG20B, KG32B KG41B-KG105</p> <p>KG10B KG20B, KG32B KG41B-KG105</p>	<p><b>M290/A3</b> <b>M290/A3.EF<sup>1</sup></b></p> <p><b>M290/A1.EF</b></p> <p><b>V840E</b></p> <p><b>V840G</b> <b>V840F</b></p> <p><b>V845</b></p> <p><b>M600</b></p>
<p>Ordering data:</p>	<p>Free shaft length or dimension from face of the switch to the cover and color selection.</p>		

<sup>1</sup>Available for switch types KG10A, KG20A and KG32A. <sup>2</sup>Only for ON/OFF switches 3 and 4 pole.

Door Clutches	Type	Code
	<p>The M280 door clutch has an adjustable shaft and can be supplied with an interlock device.</p> <p>With protected profile                      shaft fixation with set screw                      Front protection IP 40                      Front protection IP 66/67                      shaft fixation with shear ring                      Front protection IP 40                      Front protection IP 66/67</p> <p>Without protected profile                      Front protection IP 40                      Front protection IP 65</p> <p>Handle lockable with padlocks                      Protection IP 66                      The face plate is available in black, yellow and alu. The handle may be supplied in black and red.</p> <p>The M700 is a padlock door clutch and a mechanical interlocking safety device. Using the device the electrical panel may be opened only when the switch is in the OFF position and no padlock is fitted. <b>Note: Only in the ON position can knowledgeable personnel using a simple tool to defeat the interlock.</b> The M700's flexibility allows for successful installation with as much as + or - 5 mm of misalignment between the shaft and door.</p> <p>Standard handle and standard face plate                      Protection IP 66                      The M700's flexibility allows for successful installation with as much as + or - 5 mm of misalignment between the shaft and door.</p> <p>Unlock insert for the M700                      to open the door in ON-position. (After the locking has been made inactive, it is necessary to take effective precautions against an opening of the door by unauthorized persons.)</p> <p>The M800 door clutch utilizes a simple and robust design and features a compact size. It has an interlock in the ON-position while a padlock can be fitted in the OFF-position. The door clutch may be opened only if the switch is in the OFF-position. In special cases, however, authorized people have a requirement to open the door, even if the switch is in the ON-position. Further characteristics are the single hole mounting with IP 66/67 protection degree, as well as the Accepted Misalignment up to ± 3 mm horizontally and ± 5 mm vertically. Maximum 3 padlocks with a minimum shackle diameter from 5 up to 8 mm are possible.</p>	<p>KG10A                      KG20A                      KG32A                      KG41B                      KG64B                      KG80                      KG100                      KG105                      KG125-                      KG317</p> <p><b>M280E</b>  <b>M280E/.EF</b></p> <p><b>M280D</b>  <b>M280D/.EF</b></p> <p>KG41                      KG64</p> <p><b>M280B/.</b>  <b>M280B/.EF</b></p> <p>KG10B                      KG20B                      KG32B                      KG41B                      KG64B                      KG80                      KG100                      KG105                      KG125-                      KG317</p> <p><b>M700/.</b></p> <p><b>M701</b></p> <p><b>S1D M700 29</b></p> <p><b>M810/.</b>  <b>M800/.</b></p>
<p>Ordering data:</p>	<p>Dimension from face of the switch to the cover or dimension from mounting surface to cover, the interlock program and the color selection.</p>	

[< back to table of contents >](#)

Padlock Devices	Type	Code
 <p>The padlock device is an integral part of the switch.</p> <p>For 2 padlocks Operation of the locking bar from the bottom. Available in black, red and electro-gray.</p>	<p>KG10A KG20A, KG32A KG10B KG20B, KG32B KG41-KG105 KG125-KG162</p>	<p><b>V840A</b></p>
 <p>For 4 padlocks Operation of the locking bar from the front. Available in black, red and electro-gray.</p>	<p>KG10A KG20A, KG32A KG41, KG64 KG10B KG20B, KG32B KG41B, KG64B KG80-KG105 KG80C- KG105C KG125-KG317</p>	<p><b>V845</b></p>
 <p>For mounting VE2 Operation of the locking bar from the front.</p> <p>For distribution box with 70 mm depth.</p>	<p>KG10A KG20A, KG32A KG41, KG64 KG80-KG105</p>	<p><b>V840B</b></p>
 <p>Padlock device with integrated F- or B-handle. The cover disc is available in black, yellow and electro-gray. The handle may be supplied in black, red and electro-gray.</p>	<p>KG20A, KG32A KG41, KG64</p>	<p><b>V840H/..E</b></p>
<p>For 2 padlocks with F-handle</p>	<p>KG10A KG20A, KG32A KG41, KG64</p>	<p><b>V840D</b></p>
<p>For 3 padlocks with F-handle</p>	<p>KG80C- KG105C KG125-KG162</p>	<p><b>V840G</b></p>
<p>For 3 padlocks with F-handle with B-handle</p>	<p>KG10B KG20B, KG32B KG41B, KG64B KG80-KG105</p>	<p><b>V840G/B</b></p>
<p>For 4 padlocks with F-handle with B-handle</p>	<p>KG80-KG105</p>	<p><b>V840F/F</b> <b>V840F/B</b></p>
 <p>Padlock device for switches with base mounting for locking when control cabinet is opened.</p> <p>Padlock devices <b>with simplified door clutch and single hole mounting</b> see page 18.</p>	<p>KG20B, KG32B KG41B, KG64B KG80-KG105 KG125-KG317</p>	<p><b>V840VE</b></p>
<p>Ordering data:</p>	<p>For V840 and V845 color selection required.</p>	

[< back to table of contents >](#)

Additional Module for Motor Control Center (MCC), Angular drive	Type	Code
---	------	------

Angular drive

	KG125- KG317 <sup>1</sup>	<b>M330</b>
---	------------------------------	-------------

<sup>1</sup>Only for ON/OFF switches 3 and 4 pole.

<b>Selection Data</b>	KG10	KG20	KG32	KG41	KG64	KG80	KG100	KG105	KG125	KG160	KG210	KG250	KG315
	KG10A	KG20A	KG32A	KG41B	KG64B	KG80C	KG100C	KG105C	KG126	KG161	KG211	KG251	KG316
	KG10B	KG20B	KG32B						KG127	KG162	KG212	KG252	KG317

<b>Rated Insulation Voltage <math>U_i</math></b> IEC/VDE <sup>1</sup> UL/Canada CEE/NEMKO	V	690	690	690	690	690	690	690	690	1000 <sup>2</sup>	1000 <sup>2</sup>	1000 <sup>2</sup>	1000 <sup>2</sup>	1000 <sup>2</sup>		
	V	300	600	600	600	600	600	600	600	600	600	600	600	600		
	V	400	500	500	500	500	500	500	-	-	-	-	-	-		
<b>Rated Impulse Withstand Voltage <math>U_{imp}</math></b> <sup>1</sup>	kV	4	6	6	6	6	6	6	6	8	8	8	8	8		
<b>Rated Thermal Current</b> IEC/VDE $I_{u, open} = I_{th}$ $I_{the, enclosed}$ UL/Canada ON/OFF function UL/Canada Double-throw function	A	20	25	32	40	63	80	100	125	125	160	200	250	315		
	A	20	25	32	40	63	80	100	125	125	160	200	250	315		
	A	20	25	30	40	60	80 <sup>3</sup>	100 <sup>3</sup>	125	150 <sup>3</sup>	200 <sup>3</sup>	200 <sup>3</sup>	250 <sup>3</sup>	300 <sup>3</sup>		
	A	20	25	30	40	60	80 <sup>3</sup>	100 <sup>3</sup>	115	125 <sup>3</sup>	160 <sup>3</sup>	-	-	-		
<b>Rated Operational Current <math>I_e</math></b> AC-21A Switching of resistive loads, including moderate overloads	IEC/VDE	A	20	25	32	40	63	80	100	125	125	160	200	250	315	
	AC-22A Switching of combined resistive or low inductive loads, including moderate overloads	IEC/VDE	220 V-500 V	A	20	20	32	40	63	80	100	125	125	160	200	250
Ampere-Rating ON/OFF function Double-throw function Resistive or low inductive loads	UL/Canada <sup>4</sup> 600 V	A	20 <sup>7</sup>	25	30	40	60	80 <sup>3</sup>	100 <sup>3</sup>	125	150 <sup>3</sup>	200 <sup>3</sup>	200 <sup>3</sup>	250 <sup>3</sup>	300 <sup>3</sup>	
	UL/Canada <sup>4</sup> 600 V	A	20 <sup>7</sup>	25	30	40	60	80 <sup>3</sup>	100 <sup>3</sup>	115	125 <sup>3</sup>	160 <sup>3</sup>	-	-	-	
<b>Rated Utilization Category</b> AC-3 Direct-on-line starting	IEC/VDE	3 phase	220 V-240 V	kW	2,2	4	5,5	7,5	11	15	18,5	22	22	30	37	45
	3 pole	380 V-440 V	kW	3,7	5,5	7,5	11	18,5	22	30	37	37	45	55	55	75
	500 V	kW	3,7	5,5	7,5	15	22	30	37	45	45	55	75	75	90	
	690 V	kW	3,7	5,5	7,5	11	15	18,5	22	22	30	37	40	40	45	
AC-23A Frequent switching of motors or other high inductive loads	3 phase	220 V-240 V	kW	3	5,5	5,5	7,5	11	18,5	22	25	30	30	37	37	55
	3 pole	380 V-440 V	kW	5,5	7,5	11	15	22	30	37	45	45	55	75	90	110
	500 V	kW	5,5	7,5	11	18,5	30	37	45	55	55	75	90	110	132	
	690 V	kW	5,5	7,5	11	15	18,5	22	30	30	37	37	45	45	45	
DOL-Rating Standard motor load (similar AC-3)	UL/Canada <sup>4</sup> 120 V	3 phase	HP	1	2	3	5	5	10	10	15	15	20	25	30	40
	240 V	HP	2	7,5	10	15	15	25	25	40	40	40	50	60	75	75
	480 V	HP	-	15	20	25	30	50	50	60	60	60	75	75	100	100
	600 V	HP	-	20	25	30	40	50	50	50	60	60	60	75	75	100
Power loss per contact at $I_u$ Resistance to vibration <sup>5</sup> Resistance to shock <sup>5</sup>	W	0,9	0,7	1,1	1	2,2	1,7	2,4	3,8	3,1	5	5	8	12,7		
	C	A	A	A	A	A	A	A	A	C	C	C	C	C		
	C	B	B	B	B	B	B	B	B	C	C	C	C	C		
<b>Short Circuit Protection</b> Max. fuse size Rated short-time withstand current (1 s-current)	(gG-characteristic)	A	20	35	35	50	63	80	100	125	125	160	200	250	315	
	A	130	350	430	500	580	1600	1850	2000	2500	3000	4000	4600	5800		
<b>Max. Permissible Wire Gage</b> - Use copper wire only For box terminal	Single-core or stranded wire	mm <sup>2</sup>	2,5	6	6	16	16	50	50	50	95	95	185	185	185	
		AWG	12	10	10	6	6	1/0	1/0	1/0	3/0	3/0	-	-	-	
		MCM	-	-	-	-	-	-	-	-	-	-	350	350	350	
Flexible wire sleeving in accordance with DIN 46228		mm <sup>2</sup>	2,5	4	4	10	10	35	35	35	70	70	120	120	120	
		mm <sup>2</sup>	2,5	4	4	10	10	35	35	35	70	70	150	150	150	
		AWG	12	10	10	6	6	2	2	2	2/0	2/0	-	-	-	
Cable lug or track must accept connection screw	Max. width	mm	-	-	-	-	-	-	-	-	M10 x 20	M10 x 20	M12 x 20	M12 x 20	M12 x 20	
	Max. width with protective cover	mm	-	-	-	-	-	-	-	-	20	20	25	25	25	
		mm	-	-	-	-	-	-	-	-	25	25	34	34	34	
<b>Min. Ambient Temperature</b> <b>Max. Ambient Temperature</b> <sup>6</sup>	open at 100 % $I_u/I_{th}$	-5 °C														
	enclosed at 100 % $I_{the}$	50 °C during 24 hours with peaks up to 55 °C 35 °C during 24 hours with peaks up to 40 °C														

[< back to table of contents >](#)

22

<sup>1</sup>Valid for lines with common neutral termination, overvoltage category III, pollution degree 3. Values for other supply systems on request. <sup>2</sup>Suitable for no load switching applications (AC-20A) above 690 V. <sup>3</sup>Valid when connected with wire rated for 75 °C. <sup>4</sup>International Standards and Approvals, refer to page 24. <sup>5</sup>A: min. 4 g, 2-100 Hz, 1,6 mm. B: min. 6 g, 6 ms. C: on request. <sup>6</sup>Storage temperature: -40 °C to 85 °C (in case of temperature below -5 °C no shock load permissible). <sup>7</sup>Max. 277 V.

DC Switching Capacity								Rated Operational Current $I_e$ / A																		
No. of series connected contacts, total voltage / V								KG20 for utilization category						KG32 for utilization category						KG41 for utilization category						
								DC-21		DC-22		DC-23		DC-21		DC-22		DC-23		DC-21		DC-22		DC-23		
1	2	3	4	5	6	7	8	A	B	A	B	A	B	A	B	A	B	A	B	A	B	A	B	A	B	
80	160	240	320	400	480	560	640	25	25	25	25	21	21	32	32	32	32	30	30	40	40	40	40	40	40	
110	220	330	440	550	660	770	880	25	25	18	18	12	12	32	32	25	25	18	18	40	40	32	32	25	25	
140	280	420	560	700	840	1000	-	21	21	12	12	8	8	28	28	18	18	12	12	28	28	20	20	14	14	
170	340	510	680	850	1000	-	-	-	20	-	9	-	5	-	25	-	12	-	8	-	25	-	12	-	-	10
200	400	600	800	1000	-	-	-	-	18	-	6	-	3	-	23	-	8	-	5	-	23	-	8	-	-	5
230	460	690	920	1000	-	-	-	-	11	-	4	-	2	-	15	-	5	-	3	-	10	-	5	-	-	3

Auxiliary Contacts for KG Switches

Selection Data	Auxiliary contacts for:					
	KG10 KG10A KG10B	KG20 KG20B- KG32B	KG41- KG105C	KG125- KG162	KG210- KG317	

[< back to table of contents >](#)









<b>Rated Insulation Voltage <math>U_i</math></b>	IEC/VDE UL/Canada	V V	690 300	440 300	690 600	690 600	690 600
<b>Rated Thermal Current <math>I_t/I_{th}</math></b>	IEC/VDE/BS UL/Canada	A A	20 20	10 10	16 10	16 10	16 10
<b>Rated Operational Current <math>I_e</math></b>							
AC-21A	Switching of resistive loads, including moderate overloads	IEC/VDE	A	20	10	16	16
AC-15	Switching of control devices, contactors, valves etc.	110 V-240 V	A	6	2,5	6	6
		380 V-440 V	A	4	1,5	3	3
		500 V	A	-	-	1,5	1,5
Pilot Duty	Heavy	UL/Canada		A300	A300	A600	A600
Ampere-Rating	Resistive or low inductive loads	UL/Canada	A	20 <sup>1</sup>	10	10	10
<b>Short Circuit Protection</b>							
	Max. fuse size	(gG-characteristic)	A	20	10	16	16
<b>Max. Permissible Wire Gage</b> - Use copper wire only							
	Single-core or stranded wire	mm <sup>2</sup> AWG	2,5 12	1,5 14	2,5 12	2,5 12	2,5 12
	Flexible wire sleeving in accordance with DIN 46228	mm <sup>2</sup>	2,5	1,5	2,5	2,5	2,5
	Flexible wire without sleeve	mm <sup>2</sup> AWG	2,5 12	1,5 16	2,5 14	2,5 14	2,5 14

<sup>1</sup>Max. 277 V.

Tightening torque of screws

Type	Tightening torque		Type	Tightening torque		Type	Tightening torque		Type	Tightening torque		Type	Tightening torque	
KG10	0,8 Nm	7 lb-in	KG32A	1,25 Nm	11 lb-in	KG80C	3 Nm	27 lb-in	KG127	14 Nm	125 lb-in	KG250	16 Nm	140 lb-in
KG10A	0,8 Nm	7 lb-in	KG32B	1,25 Nm	11 lb-in	KG100	3 Nm	27 lb-in	KG160	14 Nm	125 lb-in	KG251	16 Nm	140 lb-in
KG10B	0,8 Nm	7 lb-in	KG41	1,8 Nm	16 lb-in	KG100C	3 Nm	27 lb-in	KG161	14 Nm	125 lb-in	KG252	16 Nm	140 lb-in
KG20	1,25 Nm	11 lb-in	KG41B	1,8 Nm	16 lb-in	KG105	3 Nm	27 lb-in	KG162	14 Nm	125 lb-in	KG315	16 Nm	140 lb-in
KG20A	1,25 Nm	11 lb-in	KG64	1,8 Nm	16 lb-in	KG105C	3 Nm	27 lb-in	KG210	16 Nm	140 lb-in	KG316	16 Nm	140 lb-in
KG20B	1,25 Nm	11 lb-in	KG64B	1,8 Nm	16 lb-in	KG125	14 Nm	125 lb-in	KG211	16 Nm	140 lb-in	KG317	16 Nm	140 lb-in
KG32	1,25 Nm	11 lb-in	KG80	3 Nm	27 lb-in	KG126	14 Nm	125 lb-in	KG212	16 Nm	140 lb-in			

Country	Authority	Mark or Standard	KG10	KG20	KG32	KG41	KG64	KG80	KG100	KG105	KG125	KG160	KG210	KG250	KG315
			KG10A	KG20A	KG32A	KG41B	KG64B	KG80C	KG100C	KG105C	KG126	KG161	KG211	KG251	KG316
			KG10B	KG20B	KG32B						KG127	KG162	KG212	KG252	KG317

USA	Underwriters Laboratories	 <sup>1</sup> oder 	●	●	●	●	●	●	●	●	●	●	●	●	●
Canada	Canadian Standards Association	 <sup>2</sup>  <sup>4</sup> oder  	●	●	●	●	●	●	●	●	●	●	●	●	●
International Electrical Commission (IEC) Recommendation	IEC 60204-1 <sup>3</sup> IEC 60947-3 <sup>3</sup>		+	+	+	+	+	+	+	+	+	+	+	+	+
China	China Quality Certification Centre	 GB/T14048.3	●	●	●	●	●	●	●	●	●	●	●	●	●
Lloyds Register EMEA			●	●	●	●	●								

● Switch approved      + Switch conforms to requirements

<sup>1</sup>Devices provided with terminals suitable to connect unprepared wires are approved under the "Listing Program" (File No. E35541, Guide No. NLRV). Devices with bolt terminals are approved under the "Recognized Component Program" (File No. E35541, Guide No. NLRV2).

<sup>2</sup>Approved by use of "UL Certification Services for Canada" (File No. E35541, Guide No. NLRV7 or NLRV8 respectively).

<sup>3</sup>IEC does not operate an approval program.

<sup>4</sup>File No. 13002, Class No. 3211-05 resp. 4652-04.

**KG switches are approved by UL and CSA as „disconnect switches for use in motor circuits“.** Switches using ring type terminations (KG127, KG162, KG212, KG252, KG317) it is necessary to make connections to separate terminals.

**Mounting**

(Additional length for auxiliary contacts see page 42)

**ON/OFF Switches 3 and 4 pole**

E	A	B	C	D1	D2	D3	E	F	G	G1 <sup>1</sup>	H	L
	KG10A	48	36	4	11-15	5	-	48	48	-	50	48,2
	KG10B	64	48	4	11-15	5	-	64	48	-	50	57,2
	KG20, KG32	30	-	4	8-11	-	3,2	20	42	13,5	54	50,8
	KG20A, KG32A	48	36	4	10-15	5	-	48	42	13,5	54	53,8
	KG20B, KG32B	64	48	4	10-15	5	-	64	42	13,5	54	53,8
	KG41, KG64	48	36	4	10-15	5	-	64	50	16	64	60,5
	KG41B, KG64B	64	48	4	10-15	5	-	64	50	16	64	60,5
	KG80, KG100, KG105	64	48	4	10-15	5	-	70	70	22	80	70,6
	KG80C, KG100C, KG105C	88	68	4	10-15	6	-	88	70	22	80	70,6
		3,46	2,68	.16	.39-.59	.24	-	3,46	2,76	.87	3,15	2,78

	A	B	C	D1	D2	G	G1 <sup>1</sup>	H	L	N	R	S	S1
KG125, KG160	88	68	5,5	13-17	6	112	38	108	96	-	-	-	-
KG126, KG161	88	68	5,5	13-17	6	112	38	110	96	45	20	36	38
KG127, KG162	88	68	5,5	13-17	6	112	38	109	96	45	20	36	38
KG210, KG250, KG315	88	68	5,5	13-17	6	145	52,5	126	103	-	-	-	-
KG211, KG212, KG251, KG252	88	68	5,5	13-17	6	145	52,5	126	103	50	26	44	52,5
KG316, KG317	88	68	5,5	13-17	6	145	52,5	126	103	50	26	52	52,5

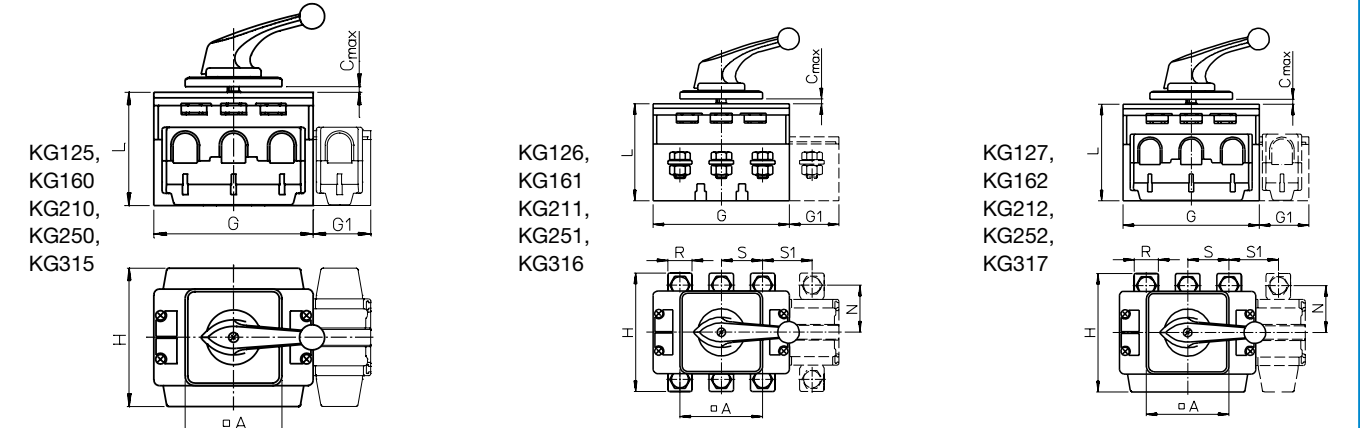

**FT1, FT2**

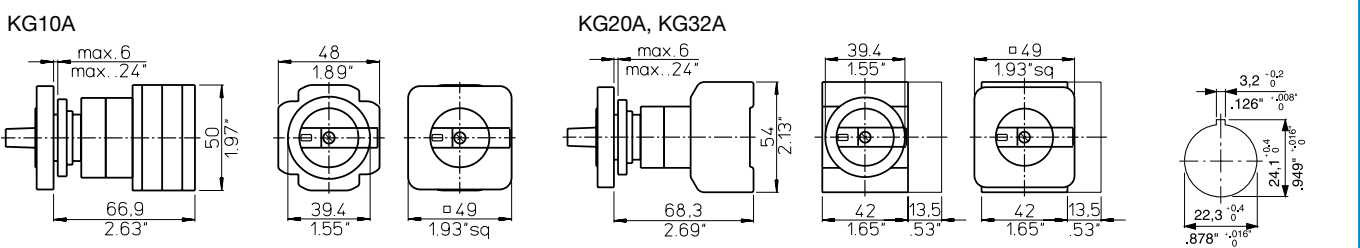

<sup>1</sup>For ON/OFF switches 4 pole.

< back to table of contents >

**Mounting**

(Additional length for auxiliary contacts see page 42)

**ON/OFF Switches 3 and 4 pole**

**VE, VE1**

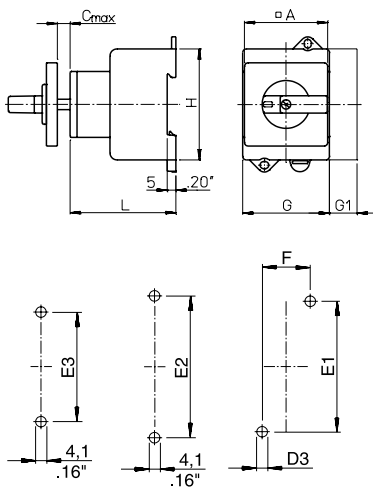

	A	B	C	D1	D2	D3	E1 <sup>1</sup>	E2 <sup>1</sup>	E3 <sup>1</sup>	F	G	G1 <sup>2</sup>	H	L	M
KG10A	48	36	12	8-15	5	4,2	60	65	50	22	48	-	50	49,5	-
	1.89	1.42	.47	.31-.59	.20	.17	2.36	2.56	1.97	.87	1.89	-	1.97	1.95	-
KG10B	64	48	29	10-15	5	4,2	60	65	50	22	48	-	50	56,5	-
	2.52	1.89	1.14	.39-.59	.20	.17	2.36	2.56	1.97	.87	1.89	-	1.97	2.22	-
KG20, KG32	30	-	12	8-11	3,2	4,1	60	-	-	-	22	42	13,5	54	50
	1.18	-	.47	.31-.43	.13	.16	2.36	-	-	-	.87	1.65	.53	2.13	1.97
KG20A, KG32A	48	36	12	8-15	5	4,1	60	-	-	-	22	42	13,5	54	50
	1.89	1.42	.47	.31-.59	.20	.16	2.36	-	-	-	.87	1.65	.53	2.13	1.97
KG20B, KG32B	64	48	13,5	10-15	5	4,1	60	-	-	-	22	42	13,5	54	50
	2.52	1.89	.53	.39-.59	.20	.16	2.36	-	-	-	.87	1.65	.53	2.13	1.97
KG41, KG64	48	36	12	10-15	5	4,1	70	-	-	-	25	50	16	64	61
	1.89	1.42	.47	.39-.59	.20	.16	2.76	-	-	-	.98	1.97	.63	2.52	2.40
KG41B, KG64B	64	48	13,5	10-15	5	4,1	70	-	-	-	25	50	16	64	61
	2.52	1.89	.53	.39-.59	.20	.16	2.76	-	-	-	.98	1.97	.63	2.62	2.40
KG80, KG100, KG105	64	48	13,5	10-15	5	5,2	90	-	-	-	25	70	22	80	68
	2.52	1.89	.53	.39-.59	.20	.21	3.54	-	-	-	.98	2.76	.87	3.15	2.68
KG80C, KG100C, KG105C	88	68	13,5	10-15	6	5,2	90	-	-	-	25	70	22	80	68
	3.46	2.68	.53	.39-.59	.24	.21	3.54	-	-	-	.98	2.76	.87	3.15	2.68

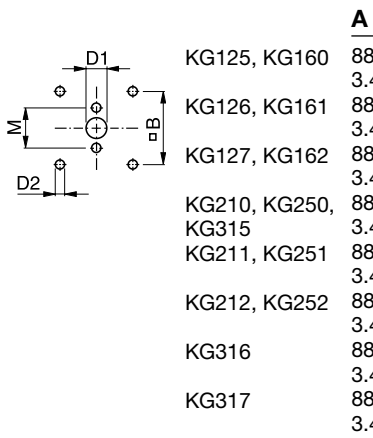

	A	B	C	D1	D2	D3	G	G1 <sup>2</sup>	H	L <sup>3</sup>	N	P	Q1	Q2	R	S	S1
KG125, KG160	88	68	16	13-17	6	6,4	112	38	108	91	-	36	59-61	59-61	-	-	-
	3.46	2.68	.63	.51-.67	.24	.25	4.41	1.50	4.25	3.58	-	1.42	2.32-2.40	2.32-2.40	-	-	-
KG126, KG161	88	68	16	13-17	6	6,4	112	38	110	91	45	36	38-40	38-40	20	36	38
	3.46	2.68	.63	.51-.67	.24	.25	4.41	1.50	4.33	3.58	1.77	1.42	1.50-1.57	1.50-1.57	.79	1.36	1.50
KG127, KG162	88	68	16	13-17	6	6,4	112	38	109	91	45	36	38-40	59-61	20	36	38
	3.46	2.68	.63	.51-.67	.24	.25	4.41	1.50	4.29	3.58	1.77	1.42	1.50-1.57	2.32-2.40	.79	1.36	1.50
KG210, KG250, KG315	88	68	16	13-17	6	6,4	145	52,5	126	98	-	44	70-72	70-72	-	-	-
	3.46	2.68	.63	.51-.67	.24	.25	5.71	2.07	4.96	3.85	-	1.73	2.76-2.83	2.76-2.83	-	-	-
KG211, KG251	88	68	16	13-17	6	6,4	145	52,5	126	98	50	44	40-42	40-42	26	44	52,5
	3.46	2.68	.63	.51-.67	.24	.25	5.71	2.07	4.96	3.85	3.94	1.73	1.57-1.63	1.57-1.63	1.02	1.73	2.07
KG212, KG252	88	68	16	13-17	6	6,4	145	52,5	126	98	50	44	40-42	70-72	26	44	52,5
	3.46	2.68	.63	.51-.67	.24	.25	5.71	2.07	4.96	3.85	1.97	1.73	1.57-1.63	2.76-2.83	1.02	1.73	2.07
KG316	88	68	16	13-17	6	6,4	145	52,5	126	98	50	44	40-42	40-42	26	52	52,5
	3.46	2.68	.63	.51-.67	.24	.25	5.71	2.07	4.96	3.85	3.94	1.73	1.57-1.63	1.57-1.63	1.02	2.05	2.07
KG317	88	68	16	13-17	6	6,4	145	52,5	126	98	50	44	40-42	70-72	26	52	52,5
	3.46	2.68	.63	.51-.67	.24	.25	5.71	2.07	4.96	3.85	1.97	1.73	1.57-1.63	2.76-2.83	1.02	2.05	2.07

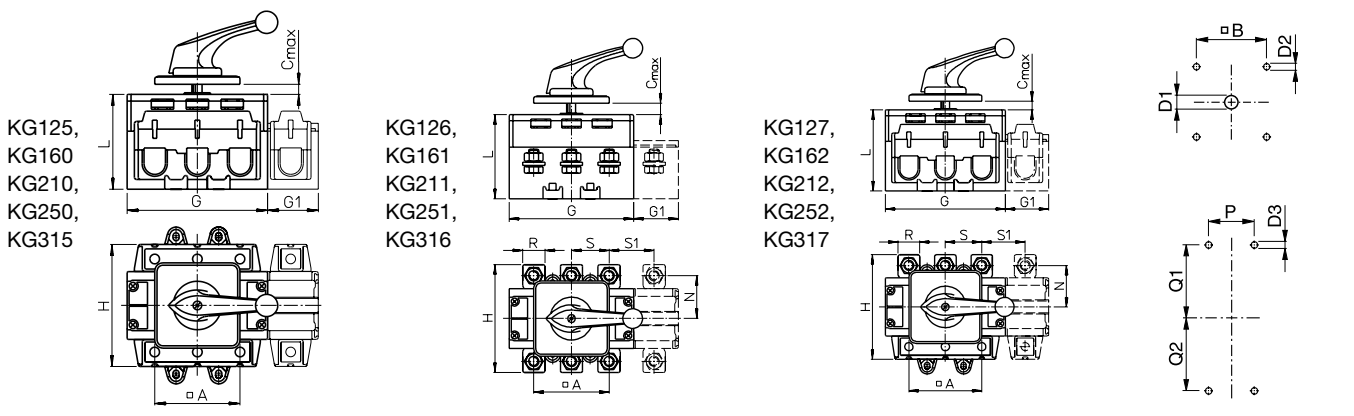

**VE2**

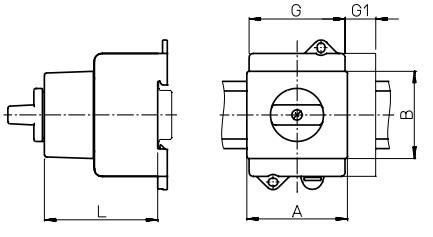

	A	B	G	G1 <sup>2</sup>	L
KG20A, KG32A	43,7	45,4	42	13,5	56,5
	1.72	1.79	1.65	.53	2.22
KG41, KG64	52,4	45,4	50	16	56,5
	2.06	1.79	1.97	.63	2.22
KG80, KG100, KG105	70	45	70	22	65
	2.76	1.77	2.76	.87	2.56
KG125-KG162	112	45	112	38	98
	4.41	1.77	4.41	1.50	3.86

**VE21**

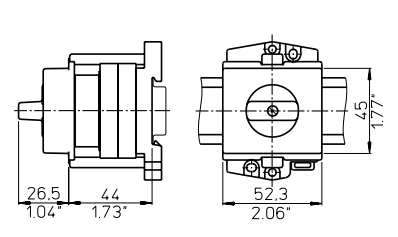

<sup>1</sup>Switches KG10A and KG10B allow use of E1, E2 or E3. <sup>2</sup>For ON/OFF switches 4 pole. <sup>3</sup>KG125-KG162 additional length for mounting VE1 = 7,5 mm/.30 inch.

< back to table of contents >

**Mounting**

(Additional length for auxiliary contacts see page 42)

**ON/OFF Switches 6 and 8 pole and Double-throw Switches**

E		A	B	C	D1	D2	F	G	G1 <sup>1</sup>	H	L <sub>6p.</sub>	L <sub>8p.</sub>	
	KG10A	48	36	4	11-15	5	48	48	-	50	57,7	67,2	
	KG10B	64	48	4	11-15	5	64	48	-	50	66,7	76,2	
	KG20A, KG32A	48	36	4	10-15	5	48	84	13,5	54	61,3	-	
	KG20B, KG32B	64	48	4	10-15	5	64	84	13,5	54	61,3	-	
	KG41B, KG64B	64	48	4	10-15	5	64	100	16	64	66,5	-	
	KG80, KG100,	64	48	4	10-15	5	70	140	22	80	81,8	-	
	KG105	2.52	1.89	.16	.39-.59	.20	2.76	5.51	.87	3.15	3.22	-	-
	KG80C, KG100C,	88	68	4	10-15	6	88	140	22	80	81,8	-	-
	KG105C	3.46	2.68	.16	.39-.59	.24	3.46	5.51	.87	3.15	3.22	-	-

KG125, KG160

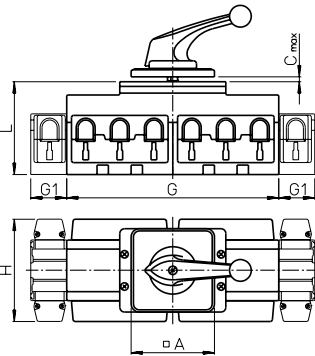

	A	B	C	D1	D2	G	G1 <sup>1</sup>	H	L	N	R	S	S1	S2
KG125, KG160	88	68	5,5	13-17	6	224	38	108	98	-	-	-	-	-
	3.46	2.68	.22	.51-.67	.24	8.82	1.50	4.25	3.86	-	-	-	-	-
KG126, KG161	88	68	5,5	13-17	6	224	38	110	98	45	20	36	38	20
	3.46	2.68	.22	.51-.67	.24	8.82	1.50	4.33	3.86	1.77	.79	1.42	1.50	.79
KG127, KG162	88	68	5,5	13-17	6	224	38	109	98	45	20	36	38	20
	3.46	2.68	.22	.51-.67	.24	8.82	1.50	4.29	3.86	1.77	.79	1.42	1.50	.79

KG126, KG161

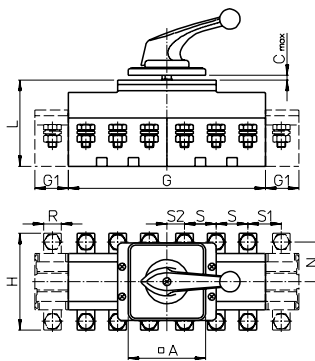

KG127, KG162

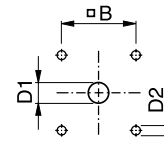
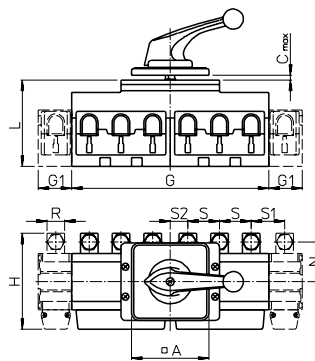

**FT1, FT2**

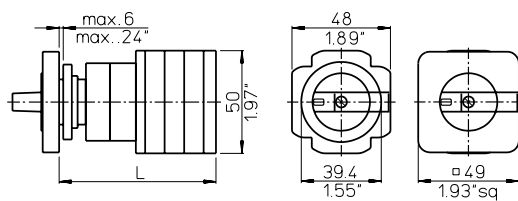

	L <sub>6p.</sub>	L <sub>8p.</sub>
KG10A	76,4	85,9
	3.01	3.38

<sup>1</sup>For ON/OFF switches 8 pole and double-throw switches 4 pole.

**Mounting**

(Additional length for auxiliary contacts see page 42)

**ON/OFF Switches 6 and 8 pole and Double-throw Switches**

**VE, VE1**

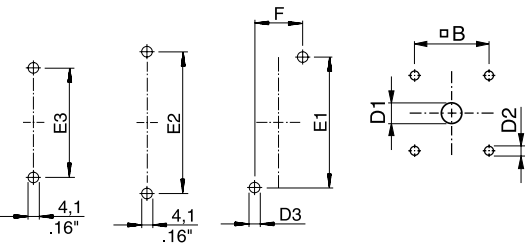
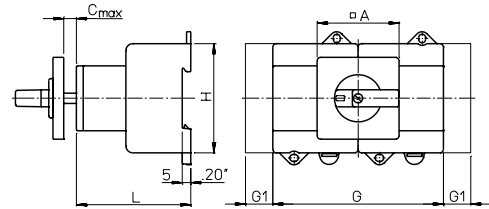

ON/OFF switches 6 pole  
double-throw switches 3 pole

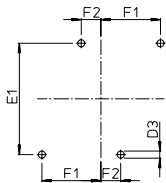

double-throw switches 4 pole

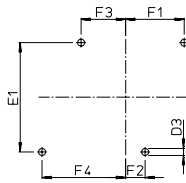

	A	B	C	D1	D2	D3	E1 <sup>1</sup>	E2 <sup>1</sup>	E3 <sup>1</sup>	F	F1
KG10A	48	36	12	8-15	5	4,2	60	65	50	22	-
KG10B	64	48	29	10-15	5	4,2	60	65	50	22	-
KG20A, KG32A	48	36	12	8-15	5	4,1	60	-	-	-	32
KG20B, KG32B	64	48	13,5	10-15	5	4,1	60	-	-	-	32
KG41B, KG64B	64	48	13,5	10-15	5	4,1	70	-	-	-	37,5
KG80, KG100	64	48	13,5	10-15	5	5,2	90	-	-	-	47,5
KG105	2,52	1,89	.53	.39-.59	.20	.16	2,36	2,56	1,97	.87	-
KG80C, KG100C	88	68	13,5	10-15	6	5,2	90	-	-	-	47,5
KG105C	3,46	2,68	.53	.39-.59	.24	.21	3,54	-	-	-	1,87

	F2	F3	F4	G	G1 <sup>2</sup>	H	L <sub>6p.</sub>	L <sub>8p.</sub>
KG10A	-	-	-	48	-	50	58,7	68,2
KG10B	-	-	-	48	-	50	65,7	75,2
KG20A, KG32A	10	23,5	45,5	84	13,5	54	57,5	-
KG20B, KG32B	10	23,5	45,5	84	13,5	54	57,5	-
KG41B, KG64B	12,5	28,5	53,5	100	16	64	67	-
KG80, KG100, KG105	22,5	44,5	69,5	140	22	80	79,2	-
KG80C, KG100C, KG105C	22,5	44,5	69,5	140	22	80	79,2	-

	A	B	C	D1	D2	D3	G	G1 <sup>2</sup>	H	L <sup>3</sup>	N	P	Q1	Q2	R	S	S1	S2
KG125, KG160	88	68	16	13-17	6	6,4	224	38	108	93	-	76	59-61	59-61	-	-	-	-
KG126, KG161	88	68	16	13-17	6	6,4	224	38	110	93	45	76	38-40	38-40	20	36	38	20
KG127, KG162	88	68	16	13-17	6	6,4	224	38	109	93	45	76	38-40	59-61	20	36	38	20

**KG125, KG160**

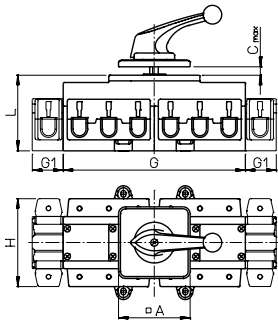

**KG126, KG161**

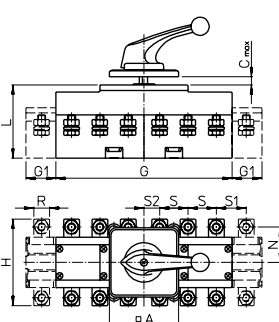

**KG127, KG162**

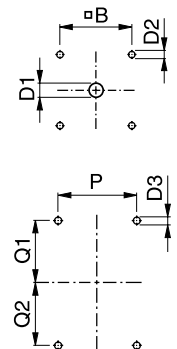
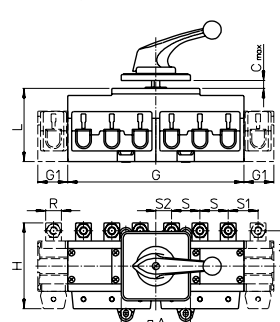

**VE2**

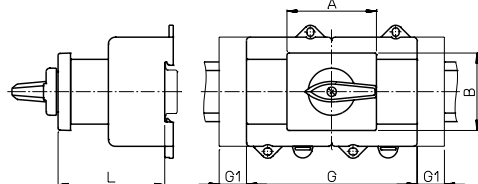

	A	B	G	G1 <sup>2</sup>	L
KG20A, KG32A	43,7	45,4	84	13,5	64
KG41B, KG64B	105,4	45,4	100	16	62,5
KG80, KG100, KG105	70	45	140	22	76,2

**VE21**

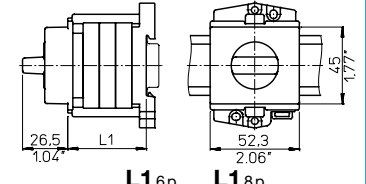

KG10A 46/1.81 54/2.13

<sup>1</sup>Switches KG10A and KG10B allow use of E1, E2 or E3. <sup>2</sup>For ON/OFF switches 8 pole and double-throw switches 4 pole. <sup>3</sup>Additional length for mounting VE1 = 7,5 mm/.30 inch.

Plastic Enclosures and Optional Extras

Switches in Plastic Enclosure

KL <sup>1</sup> ., CL <sup>1</sup> ., KS <sup>1</sup> ., CS <sup>1</sup> .	3 and 6 pole, 4 pole		8 pole, Double-throw		A	B	C	D1	D2	D3	E	F	H
	Switches	3 pole	Switches	4 pole									
	KG10 <sup>1</sup>	x	x	x	120	85	110	2x20/25 <sup>2</sup>	20	4,2	-	-	80
	KG20 <sup>1</sup>	x			4.72	3.35	4.33	2x.79/.98 <sup>2</sup>	.79	.17	-	-	3.15
	KG20, KG32	x			120	85	110	2x20/25 <sup>2</sup>	20	4,2	-	-	80
	KG20B, KG32B		x		4.72	3.35	4.33	2x.79/.98 <sup>2</sup>	.79	.17	-	-	3.15
				x	160	85	150	2x20/25	20	4,2	-	-	80
					6.30	3.35	5.91	2x.79/.98	.79	.17	-	-	3.15
					190	100	178	2x25	25	5,6	-	-	91
					7.48	3.94	7.01	2x.98	.98	.22	-	-	3.58
				x	250	145	-	2x25/40	25	6,5	124	229	107
					9.84	5.71	-	2x.98/1.57	.98	.26	4.88	9.02	4.21
	KG41, KG64	x		190	100	178	2x25	25	5,6	-	-	91	
	KG41B, KG64B		x	7.48	3.94	7.01	2x.98	.98	.22	-	-	3.58	
			x	250	145	-	2x25/40	25	6,5	124	229	107	
				9.84	5.71	-	2x.98/1.57	.98	.26	4.88	9.02	4.21	
	KG80, KG100, KG105	x		250	145	-	2x25/40	25	6,5	124	229	107	
				9.84	5.71	-	2x.98/1.57	.98	.26	4.88	9.02	4.21	

< back to table of contents >

PFA-PFF5

PFA-PFF5	3 and 4 pole		6 and 8 pole, Double-throw		A	B	E	F	H	D3
	Switches	3 pole	Switches	4 pole						
	KG20A, KG32A, KG41, KG64	x			135	92	78	110	91	4,4
	KG20B, KG32B, KG41B, KG64B		x		5.31	3.62	3.07	4.33	3.58	.17
	KG80, KG100			x	180	140	128	150	98	4,5
					7.09	5.51	5.04	5.91	3.86	.18
				x	180	140	128	150	98	4,5
					7.09	5.51	5.04	5.91	3.86	.18

Cam/rack-operated Auxiliary Contacts

E	VE	Mounting	A		M	
			allows use of 1 or 2 contacts	allows use of 3 or 4 contacts	allows use of 1 or 2 contacts	allows use of 3 or 4 contacts
		KG20, KG32	E/VE	-	9	25,8
		KG41, KG64	E/VE	-	.35	1.02
		KG80, KG100, KG105	E	-	.39	1.18
		VE	47,2	10	30	
		VE2	1.86	.39	1.18	
			47,2	20	40	
			1.86	.79	1.57	
		<b>Mounting</b>	<b>M</b>			
		KG125-KG317	E	21	.83	

Lateral mounted Auxiliary Contacts

Lateral mounted Auxiliary Contacts	M
KG41, KG41B, KG64, KG64B	.39
KG80, KG80C, KG100, KG100C, KG105, KG105C	11
KG125-KG317	.43
	11
	.43
	14
	.55

<sup>1</sup>KS<sup>1</sup>., CS<sup>1</sup>..

**Optional Extras**

**Ground and Neutral Terminal, Additional Main Contact**

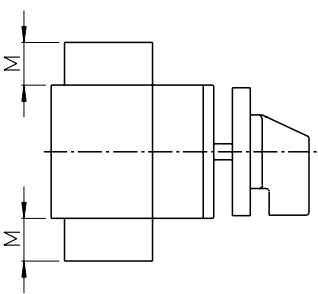

	<b>M</b>
KG20, KG20A, KG20B, KG32, KG32A, KG32B	13,5 .53
KG41, KG41B, KG64, KG64B	16 .63
KG80, KG80C, KG100, KG100C, KG105, KG105C	22 .87
KG125, KG126, KG127, KG160, KG161, KG162	38 1.50
KG210, KG211, KG212, KG250, KG251, KG252, KG315, KG316, KG317	52,5 2.07

**Protective Cover**

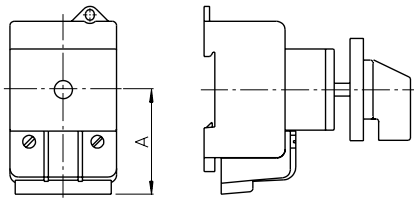

	<b>A</b>
KG10A, KG10B	30 1.18
KG20, KG20A, KG20B, KG32, KG32A, KG32B	47 1.85
KG41, KG41B, KG64, KG64B	49 1.93
KG80, KG80C, KG100, KG100C, KG105, KG105C	66 2.60

**With box terminal**



		<b>A</b>
KG125-KG162	with box terminal	76,2 3.00
	with bolt terminal	112 4.41
KG210-KG317	with box terminal	88 3.46
	with bolt terminal	160 6.30

**With bolt terminal**



		<b>A</b>
KG125-KG162	with box terminal	76,2 3.00
	with bolt terminal	112 4.41
KG210-KG317	with box terminal	88 3.46
	with bolt terminal	160 6.30

[< back to table of contents >](#)

Optional Extras

Shaft Extension

**L100, L100A**

L1 = Free shaft length

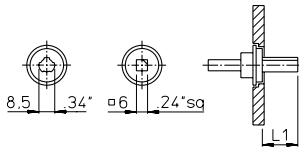

	Mounting	L1	L1	L1	L1	L1	L1	L1	L1
KG10B	E	19	23	27	32	37	42	47	52
	VE	.75	.91	1.06	1.26	1.46	1.65	1.85	2.05
KG20B, KG32B	E	11,5	16,5	20,5	24,5	29,5	34,5	39,5	44,5
	VE	.45	.65	.81	.96	1.16	1.36	1.56	1.75
KG41B, KG64B	E	13,5	17,5	21,5	26,5	31,5	36,5	41,5	46,5
	VE	.53	.69	.85	1.04	1.24	1.44	1.63	1.83
KG80, KG80C	E	15,8	19,8	23,8	28,8	33,8	38,8	43,8	48,8
	VE	.62	.78	.94	1.13	1.33	1.53	1.72	1.92
KG100, KG100C	E	13,5	17,5	21,5	26,5	31,5	36,5	41,5	46,5
	VE	.53	.69	.85	1.04	1.24	1.44	1.63	1.83
KG105, KG105C	E	16,5	20,5	24,5	29,5	34,5	39,5	44,5	49,5
	VE	.65	.81	.96	1.16	1.36	1.56	1.75	1.95
		<b>L1</b>	<b>L1</b>	<b>L1</b>	<b>L1</b>	<b>L1</b>	<b>L1</b>	<b>L1</b>	<b>L1</b>
KG10B	E	62	67	72	77	82	87	92	97
	VE	2.44	2.64	2.83	3.03	3.23	3.43	3.62	3.82
KG20B, KG32B	E	61	66	71	76	81	86	91	96
	VE	2.40	2.60	2.80	2.99	3.19	3.39	3.58	3.78
KG41B, KG64B	E	54,5	59,5	64,5	69,5	74,5	79,5	84,5	89,5
	VE	2.15	2.34	2.54	2.74	2.93	3.13	3.33	3.52
KG80, KG80C	E	61	66	71	77	81	86	91	96
	VE	2.40	2.60	2.80	3.03	3.19	3.39	3.58	3.78
KG100, KG100C	E	56,5	61,5	66,5	71,5	76,5	81,5	86,5	91,5
	VE	2.22	2.42	2.62	2.81	3.01	3.21	3.41	3.60
KG105, KG105C	E	58,8	63,8	68,8	73,8	78,8	83,8	88,8	93,8
	VE	2.31	2.51	2.71	2.91	3.10	3.30	3.50	3.69
KG125, KG126	E	56,5	61,5	66,5	71,5	76,5	81,5	86,5	91,5
	VE	2.22	2.42	2.62	2.81	3.01	3.21	3.41	3.60
KG127, KG160	E	59,5	64,5	69,5	74,5	79,5	84,5	89,5	94,5
	VE	2.34	2.54	2.74	2.93	3.23	3.33	3.52	3.72

**M004, M004A, M004D, M004E**

L1 = Free shaft length

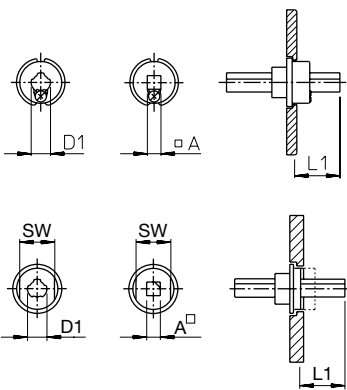

	Mounting	L1 <sup>1</sup>	L1	L1	L1	L1	D1	A	SW
KG10A	E, VE	-	21-41	41-61	61-81	81-101	6	-	12
			.83-1.61	1.61-2.40	2.40-3.19	3.19-3.98	.24	-	.47
KG20A, KG32A	E	-	34,5-38	54,5-58	74,5-78	94,5-98	6	-	12
	VE	-	1.36-1.50	2.15-2.28	2.93-3.07	3.72-3.86	.24	-	.47
KG41B, KG64B	E	-	41,5-45	61,5-65	81,5-85	101,5-105	6	-	12
	VE	-	1.63-1.77	2.42-2.56	3.21-3.35	4.00-4.13	.24	-	.47
KG80, KG80C	E	29,5-35,5	43-49	63-69	83-89	103-109	8,5	6	16
	VE	1.16-1.40	1.69-1.93	2.48-2.72	3.27-3.50	4.06-4.29	.33	.24	.63
KG100, KG100C	E	32,5-38,5	46-52	66-72	86-92	106-112	8,5	6	16
	VE	1.28-1.52	1.81-2.05	2.60-2.83	3.39-3.62	4.17-4.41	.33	.24	.63
KG105, KG105C	E	25,5-31,5	39-45	59-65	79-85	99-105	8,5	6	16
	VE	1.00-1.24	1.54-1.77	2.32-2.56	3.11-3.35	3.90-4.13	.33	.24	.63
KG125, KG126	E	30,5-36,5	44-50	64-70	84-90	104-110	8,5	6	16
	VE	1.20-1.44	1.73-1.97	2.52-2.76	3.31-3.54	4.09-4.33	.33	.24	.63
KG127, KG160	E	39-53	69-83	99-113	129-143	159-173	11,2	8	22
	VE	1.54-2.09	2.72-3.27	3.90-4.45	5.08-5.63	6.26-6.81	.44	.32	.87
KG161, KG162	E	44-58	74-88	104-118	134-148	164-178	11,2	8	22
	VE	1.73-2.28	2.91-3.46	4.09-4.65	5.28-5.83	6.46-7.01	.44	.32	.87
KG210, KG211	E	38-52	68-82	98-112	128-142	158-172	11,2	8	22
	VE	1.50-2.03	2.68-3.23	3.86-4.41	5.04-5.59	6.22-6.77	.44	.32	.87
KG212, KG250	E	43-57	73-87	103-117	133-147	163-177	11,2	8	22
	VE	1.69-2.24	2.87-3.43	4.06-4.61	5.24-5.78	6.42-6.97	.44	.32	.87
KG251, KG252	E	43-57	73-87	103-117	133-147	163-177	11,2	8	22
	VE	1.69-2.24	2.87-3.43	4.06-4.61	5.24-5.78	6.42-6.97	.44	.32	.87
KG315, KG316	E	43-57	73-87	103-117	133-147	163-177	11,2	8	22
	VE	1.69-2.24	2.87-3.43	4.06-4.61	5.24-5.78	6.42-6.97	.44	.32	.87
KG317									

<sup>1</sup>Only for square shaft

Optional Extras

Simplified Door Clutches

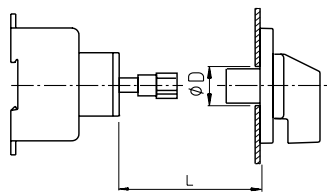

**M290/A3, M290/A3.EF** L = Standard length for switches of mounting VE

	L	L	L	L	L	D <sup>1</sup>
KG10A	37-57	57-77	77-97	97-117	-	18
	1.46-2.24	2.24-3.03	3.03-3.82	3.82-4.61	-	.71
KG20A, KG32A	55-68	75-88	95-108	115-128	-	18
	2.17-2.68	2.95-3.46	3.74-4.25	4.53-5.04	-	.71
KG41B, KG64B	60-70	80-90	100-110	120-130	-	18
	2.36-2.76	3.15-3.54	3.94-4.33	4.72-5.12	-	.71
KG80, KG100	56-68	76-88	96-108	116-128	-	18
KG105	2.20-2.68	2.99-3.46	3.78-4.25	4.57-5.04	-	.71

<sup>1</sup>For KG10A, KG20A and KG32A with M290/A3.EF: 22/.87

**M290/A1.EF** L = Standard length for switches of mounting VE

	L	L	L	L	L	D
KG41B, KG64B	27-31	27-38	32-45	41-54	47-60	56-69
	1.06-1.22	1.06-1.50	1.26-1.77	1.61-2.13	1.85-2.36	1.97-2.72
KG80, KG100	27-32	27-40	33-47	42-55	48-62	57-70
KG105	1.06-1.26	1.06-1.57	1.30-1.85	1.65-2.17	1.89-2.44	2.24-2.76

**V840E**

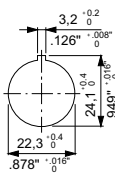
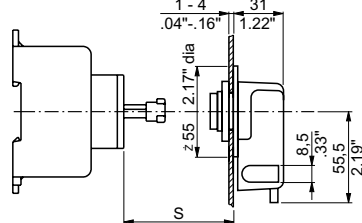

	S	
	min.	max.
KG10B	23	106
	.91	4.17
KG20B, KG32B	24,5	110
	.96	4.33
KG41B, KG64B	20	108
	.79	4.25
KG80, KG100	23	109
KG105	.91	4.29
KG125-KG317	21	110
	.83	4.33

**V840G/V840F**

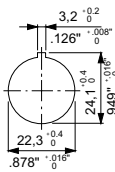
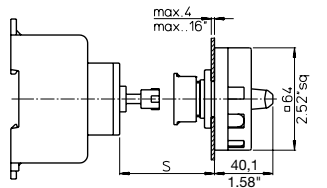

	S	
	min.	max.
KG10B	30	115
	1.02	4.49
KG20B, KG32B	27,5	113
	1.08	4.45
KG41B, KG64B	39,5	124
	1.56	4.88
KG80, KG100	27,5	122
KG105	1.08	4.80

**V845**

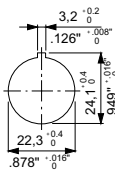
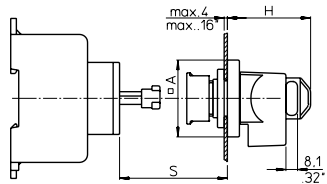

	A	H	S	
			min.	max.
KG10A	48	52	30	115
	1.89	2.05	1.18	4.53
KG10B	64	58	26	114
	2.52	2.28	1.02	4.49
KG20A, KG32A	48	52	50,5	119
	1.89	2.05	1.99	4.69
KG20B, KG32B	64	58	27,5	113
	2.52	2.28	1.08	4.45
KG41B, KG64B	64	58	39,5	124
	2.52	2.28	1.56	4.88
KG80, KG100	64	58	27,5	122
KG105	2.52	2.28	1.08	4.80

**M600**

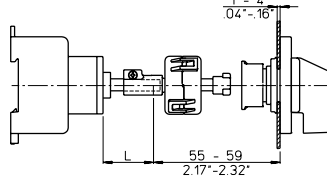

L see L100, M004D, M004, page 44.

Door Clutches

**M700/.**

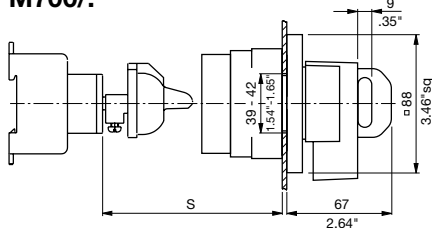

**M701**

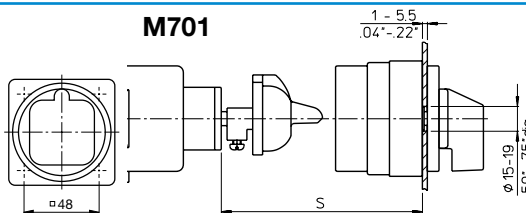

	S
KG10B	80
	3.15
KG20B, KG32B	61,5
	2.42
KG41B, KG64B	61,5
	2.42
KG80, KG100	61,5
KG105	2,42
KG125-KG317	61,5
	2.42

Optional Extras

Simplified Door Clutches

M810

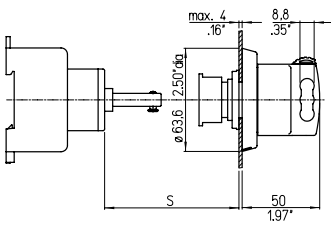

M800

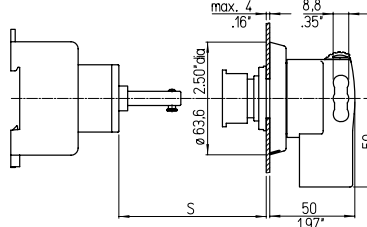

M810, M800

		S
KG41B, KG64B	3-pole	59
	6-pole	57
KG80, KG100 KG105	3-pole	56
	6-pole	53
KG125-KG317		56
		2.20

KG10A, KG20A, KG32A

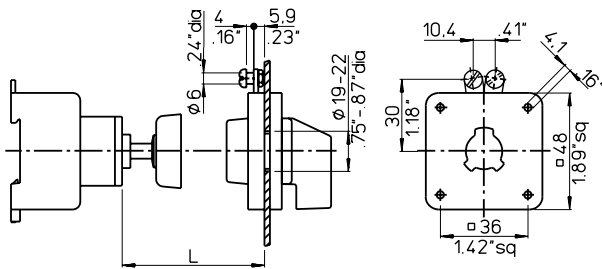

M280D, M280D/.EF, M280E, M280E/.EF

L = Standard length for switches of mounting VE

	L	L	L	L
KG10A	36-55	56-75	75-95	96-116
KG20A, KG32A	1.42-2.17	2.20-2.95	2.99-3.74	3.78-4.57
	58,5-66	78,5-86	98,5-106	118,5-126
	2.30-2.60	3.09-3.50	3.88-4.17	4.67-4.96

KG10B, KG20B, KG32B, KG41B, KG64B, KG80, KG100, KG105

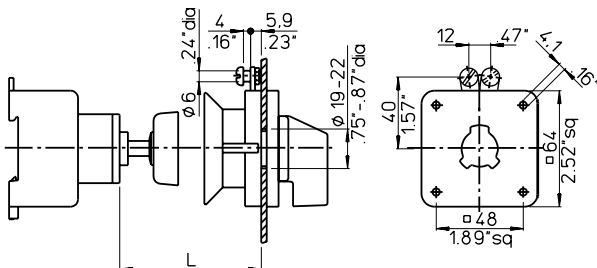

	L	L	L	L
KG10B	32-57	58-77	78-97	98-118
KG20B, KG32B	1.26-2.24	2.28-3.03	3.07-3.82	3.86-4.65
	57,5-65	77,5-85	97,5-105	117,5-125
KG41B, KG64B	2.26-2.56	3.05-3.35	3.84-4.13	4.63-4.92
	62-72	82-92	102-112	122-132
KG80, KG100 KG105	2.44-2.83	3.23-3.62	4.02-4.41	4.80-5.20
	60-70	80-90	100-110	120-130
	2.36-2.76	3.15-3.54	3.94-4.33	4.72-5.12

KG125-KG317

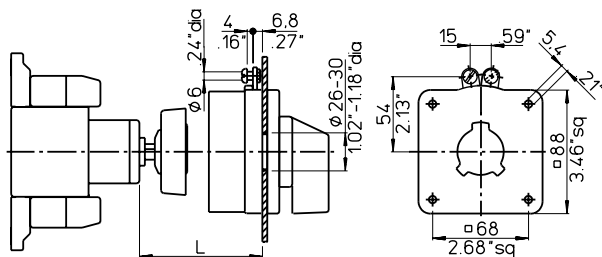

	L	L	L	L
KG125-KG317	93-109	123-139	153-169	183-199
	3.66-4.29	4.84-5.47	6.02-6.65	7.20-7.83

M280B/., M280B/.EF

L = Standard length for switches of mounting VE

	L	L	L	L
KG41, KG64	26-34	41-49	56-64	71-79
	1.02-1.34	1.61-1.93	2.20-2.52	2.80-3.11

< back to table of contents >

Optional Extras

Padlock Devices, Additional Module for Motor Control Center (MCC), Angular drive

V840A

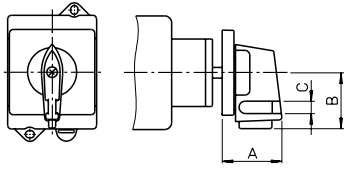

KG10A, KG20A, KG32A, KG41  
KG64  
KG10B, KG20B, KG32B, KG41B  
KG64B, KG80, KG100, KG105

A	B	C
32,9	31,5	5
1.30	1.24	.20
41,6	40	7
1.64	1.57	.28

V840B

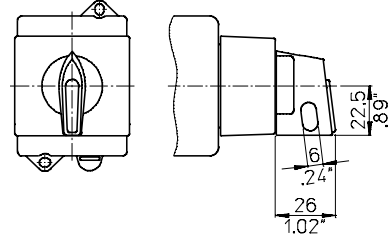

V845

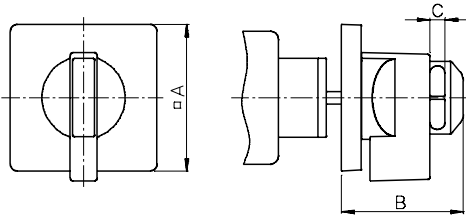

KG10A, KG20A, KG32A, KG41  
KG64  
KG10B, KG20B, KG32B, KG41B  
KG64B, KG80, KG100, KG105  
KG80C, KG100C, KG105C  
KG125-KG317

A	B	C
48	51	7,2
1.89	2.01	.28
64	58	8,1
2.52	2.28	.32
88	73	9
3.47	2.87	.35

V840D

KG10A, KG20A, KG32A, KG41, KG64

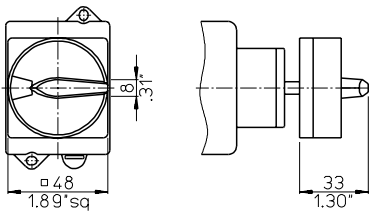

V840D

KG80C, KG100C, KG105C, KG125-KG162

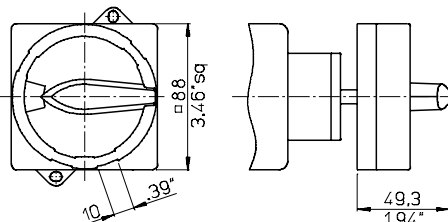

V840G/B, V840F/B

KG10B, KG20B, KG32B, KG41B, KG64B,  
KG80, KG100, KG105

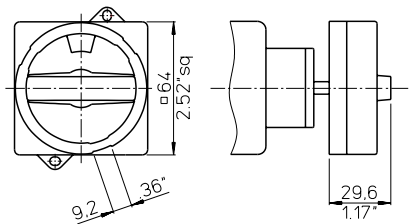

V840G, V840F/F

KG10B, KG20B, KG32B, KG41B, KG64B,  
KG80, KG100, KG105

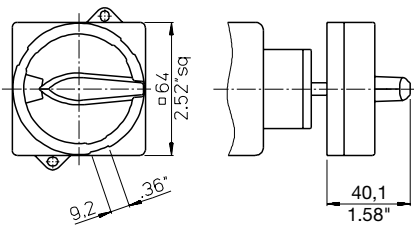

V840H/..E

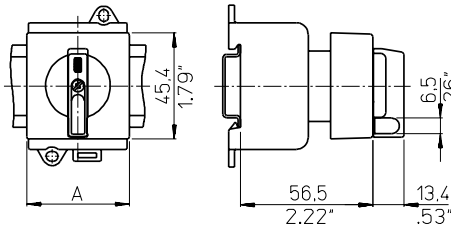

	A
KG20A, KG32A	43,7 1.72
KG41, KG64	52,4 2.06

V840VE

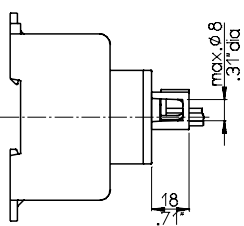

V500

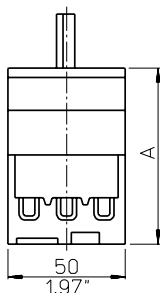

A	
69,5	KG20B
2.74	KG32B
75	KG41B
2.95	KG64B

M330

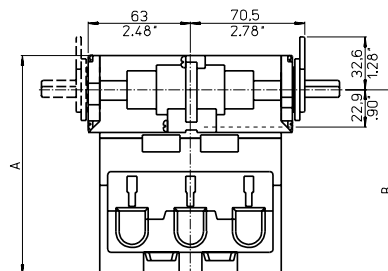

	A	B
KG125-	135	113,9
KG162	5.31	4.48
KG210-	142	120,9
KG317	5.59	4.76



---

# The Range of “Blue Line” Switchgear

Technical literature covering the following products is available on request.

	Catalog Number
<b>Main Switches and Main Switches with Emergency Function 16 A-315 A</b> <b>Maintenance Switches 20 A-315 A</b> <b>Switch Disconnectors 20 A-315 A</b> According to IEC 60947-3, EN 60947-3, VDE 0660 part 107, IEC 60204, EN 60204 and VDE 0113	<b>500</b>
<b>CL Switches 10 A-20 A</b> <b>C, CA and CAD Switches 10 A-315 A and L Switches 350 A-2400 A</b> C, CA and CAD switches are designed for universal application. They are recommended for instrument, isolator, double-throw and motor control. L switches are designed for load and off-load applications. They are used to switch resistive or low inductive loads.	<b>100</b>
<b>Optional Extras and Enclosures</b> The complete product line, a large number of optional extras is available, including door interlocks, push-pull devices, cylinder and padlock attachments, control and indicator devices, AC motor drives, as well as enclosures, both insulated and metal.	<b>101</b>
<b>A and AD Switches 6 A-25 A</b> A and AD switches have 4 contacts in each switching stage. These switches provide an extensive range of switch functions and require a minimum mounting depth. Up to 36 switching positions are possible, with availability of 48 contacts per 12 stage switch column.	<b>110</b>
<b>CG, CH and CHR Switches 10 A-25 A</b> Ultra compact CG, CH and CHR switches are ideally suited for control and instrumentation applications. Switch terminals are “finger-proof” and conveniently accessible for wiring and are delivered open. All CG4 switches offer specially designed gold plated contacts or H-bridges with “cross-wire” contact systems, which facilitates their use in electronic circuitry and chemically aggressive environments.	<b>120</b>
<b>DH, DHR, DK and DKR Switches 6 A-16 A</b> DH, DHR, DK and DKR switches incorporate unique corrosion resistant contacts that permit operation on system voltage as low as 1 V. They have fully enclosed and protected contacts which can be operated either by rotary and/or lateral handle movement. D switches are used in calibration and semiconductor circuits. They are also used for relay and contactor control.	<b>130</b>
<b>X Switches 80 A-630 A</b> X switches can be applied for load, tap and gang switching duties. They incorporate 6 contacts in each switching stage. Their compact design provides a minimum length dimension for mounting purposes.	<b>140</b>
<b>KG Switches 20 A-315 A</b> KG switches are excellent circuit interruptors. They have high through fault and fault making capacities and are especially designed for use as isolators and safety switches for machine tools, distribution panels and switchboards. KG ON/OFF switches offer unusually high dimensioned air and creepage distances between terminals which are designed for time saving “straight-line” wiring. ON/OFF switches are available with up to 8 poles and double-throw switches are available with up to 4 poles.	<b>150</b>
<b>Push Buttons and Pilot Lights, 22,5 mm Ø</b> A complete range of state-of-the-art push buttons and pilot lights represent an ideal combination of functional security and economical efficiency in a modular design.	<b>302</b>

**Australia**

Kraus & Naimer Pty. Ltd.  
379 Liverpool Road, ASHFIELD, N.S.W. 2131  
P: 1800 567 948  
E: sales-au@krausnaimer.com

**Austria**

Kraus & Naimer GmbH  
Schumannngasse 39  
1180 WIEN  
P: +43 1 404 06 0  
E: sales-at@krausnaimer.com

**Belgium, Luxembourg**

Kraus & Naimer B.V.  
Ikaros Business Park  
Ikaroslaan 83  
1930 ZAVENTHEM  
P: +32 2 757 0141  
F: +32 2 757 1640  
E: sales-be@krausnaimer.com

**Brazil**

**Central and South America**  
Kraus & Naimer Ind. Com. Ltda.  
Rua Santa Monica, 1061  
Parque Industrial San Jose  
P: +55 11 2198 1288  
F: +55 11 2198 1251  
E: knbrasil@krausnaimer.com.br

**Canada**

Kraus & Naimer Ltd.  
219 Connie Crescent, Unit 13A  
CONCORD, Ontario, L4K 1L4  
P: +1 905 738 1666  
E: sales-ca@krausnaimer.com

**Cyprus**

ELECTROMATIC CONSTRUCTIONS LTD.  
72, Evagoras Pallikarides Str., 2235 LATSIA-Nicosia  
P. O. Box 12630, 2251 LATSIA-Nicosia  
P: +357 2 48 41 41  
F: +357 2 48 57 47  
E: electromatic@cytanet.com.cy

**Czech Republic**

OBZOR, výrobní družstvo Zlín  
Na Slanici 378  
763 02 ZLÍN  
P: +420 577 195 150  
F: +420 577 195 152  
E: odbyt@obzor.cz

**Denmark**

THIIM A/S  
Transformervej 31  
2860 SOEBORG  
P: +45 4485 8000  
F: +45 4485 8005  
E: thiim@thiim.com

**Finland**

Kraus & Naimer Oy  
Kiitoradankuja 8  
01530 VANTAA  
P: +358 9 825 424 0  
E: sales-fi@krausnaimer.com

**France**

Kraus & Naimer s.a.s.  
33, rue Bobillot  
75013 PARIS  
P: +33 1 58 40 80 80  
E: sales-fr@krausnaimer.com

**Germany**

Kraus & Naimer GmbH  
Wikingerstraße 20-28, 76189 KARLSRUHE  
Postfach 10 01 24, 76231 KARLSRUHE  
P: +49 721 59 88 0  
E: sales-de@krausnaimer.com

**Great Britain**

Kraus & Naimer Ltd.  
115 London Road  
NEWBURY/BERKSHIRE RG14 2AH  
P: +44 1635 262626  
F: +44 1635 37807  
E: sales-uk@krausnaimer.com

**Greece**

KALAMARAKIS-SAPOUNAS S. A.  
Ionias & Neromilou Str., P. O. Box 46566  
13671 ACHARNES/ATHENS  
P: +30 2 10 240 6000 6  
F: +30 2 10 240 6007  
E: kalamarakis.sapounas@ksa.gr

**Hungary**

GANZ KK KFT.  
X. Kőbányai út 41/c, Postfach 87  
1475 BUDAPEST  
P: +36 1 261 5479  
E: ganzkk@ganzkk.hu

**Iceland**

JOHAN RÖNNING LTD.  
Klettagarðar 25  
104 REYKJAVIK  
P: +354 5200 800  
E: ronning@ronning.is

**Republic of Ireland**

Kraus & Naimer Ltd.  
4235 Atlantic Avenue  
Westpark Business Campus  
Shannon, Co. Clare  
P: +353 61 704700  
F: +353 61 471084  
E: sales-ie@krausnaimer.com

**Italy**

Kraus & Naimer s.r.l.  
Via Terracini, 9  
24047 TREVIGLIO (BG)  
P: +39 0363 30 11 12  
E: sales-it@krausnaimer.com

**Japan**

Kraus & Naimer Ltd.  
Yoshiwada Building 2F  
1-11-6 Hamamatsucho  
Minato-Ku, TOKYO 105-0013  
P: +81 3 3436 6151  
F: +81 3 3436 6325  
E: sales-jp@krausnaimer.com

**Mexico**

JC INGENIERÍA Y CONTROL, SA DE CV.  
Ángel Gaviño 30,  
C. Satélite, C. Medicos,  
Naucalpan Edo. de Mexico, C.P. 53100  
P: +52 55 55 62 75 77  
F: +52 55 55 62 04 34  
E: ventas@jcingenieriacontrol.com

**Netherlands**

Kraus & Naimer B.V.  
Wegtersweg 38  
7556 BR HENGELO  
P: +31 74 291 9441  
F: +31 74 291 98380  
E: sales-nl@krausnaimer.com

**New Zealand**

Kraus & Naimer Ltd.  
42 Miramar Avenue, WELLINGTON 6022  
P. O. Box 15-009, WELLINGTON 6243  
P: + 64 0800 736 522  
E: sales-nz@krausnaimer.com

**Norway**

Kraus & Naimer AB Avd. Norge  
c/o Tim Figved  
Gurinstubben 27  
0584 Olso  
T: +47 22 64 44 20  
E: sales-no@krausnaimer.com

**Poland**

ASTAT LOGISTYKA SP. Z O.O.  
Dąbrowskiego 441  
60451 POZNAŃ  
P: +48 61 849 80 89  
E: k.swiderski@astat.pl

**Portugal**

ELECTRICOL-DAMAS, FERREIRA & DAMASCENO, LDA.  
Apartado 1063, S. Ant. Cavaleiros  
2670 LOURES  
P: +351 21 989 8939  
F: +351 21 988 6464  
E: electricol@electricol.pt

**Singapore, India, Middle East – UAE**

Kraus & Naimer Pte. Ltd.  
988 Toa Payoh North  
#05-01/02/07/08  
SINGAPORE 319002  
T: +65 6473 8166  
E: sales-sg@krausnaimer.com

**Slovenia**

SCHRACK TECHNIK D.O.O.  
Pameče 175  
SI-2380 SLOVENJ GRADEC  
P: +386 2 88 392 00  
F: +386 2 88 434 71  
E: d.goljat@schrack.si

**Republic of South Africa**

Kraus & Naimer Pty. Ltd.  
7 Village Crescent, Linbro Village  
Linbro Business Park, SANDTON 2065  
P. O. Box 511, KELVIN 2054  
P: +27 11 608 6060  
E: sales-za@krausnaimer.com

**Spain**

Kraus & Naimer B.V.  
P: +34 662 696 014  
E: sales-es@krausnaimer.com

**Sweden**

Kraus & Naimer AB  
Dr. Widerströms Gata 11, Hägersten  
Box 42097, 126 14 STOCKHOLM  
P: +46 8 97 00 80  
E: sales-se@krausnaimer.com

**Switzerland**

AWAG Elektrotechnik AG  
Sandbühlstraße 2  
CH-8604 VOLKETSCHWIL  
P: +41 44 908 19 19  
E: info@awag.ch

**Turkey**

KARDES ELEKTRİK SANAYİ VE TİCARET A.Ş.  
Yassıoren Mah. Hıfıa Sok. No: 4  
34277 Arnavutköy-Istanbul-Turkey  
P: +90 212 624 92 04 118  
F: +90 212 592 48 10  
E: info@unalkardes.com.tr

**USA**

Kraus & Naimer Inc.  
760 New Brunswick Road  
SOMERSET, NJ 08873  
P: +1 732 560 1240  
E: sales-us@krausnaimer.com



Kraus & Naimer

---



---

**Contact us:**

[www.krausnaimer.com](http://www.krausnaimer.com)